



BR 01a · PTFE-lined Globe Control Valve

Single-seated Globe Valve · DIN and ANSI Version



Applications

PTFE-lined control valve for corrosive media, particularly for severe requirements in chemical applications:

- **Nominal size DN 25 to 200 and NPS1 to 8**
- **Nominal pressure PN 10, PN 16 and cl150**
- **Temperatures -10 °C to +200 °C (14 °F to 392 °F)**

The control valve consists of a single-seated globe valve with PTFE- lining and either a pneumatic actuator or hand-operated actuator. The control valve with its modular design has the following features:

- Streamlined valve body made of spheroidal graphite iron (EN-JS 1049/A 395) with 5-8 mm thick PTFE lining
- Exchangeable PTFE seat and PTFE plug
- Stem sealed by a PTFE bellows seal and a backup packing
- Test connection for monitoring of the PTFE bellows seal
- Exchangeable actuator
- Additional equipment can be mounted according to IEC 60534 and NAMUR Recommendation
- Face-to-face dimensions according to DIN EN 558, basic series 1 and 37 (NPS1 to 4)

Versions

The BR 01a Control valve is available optionally in the following versions:

- With SAMSON pneumatic actuator
- With SAMSON hand-operated actuator
- With actuators of other manufacturers on request

Special designs

- Heating of the valve body with heating jacket
- Lining made of special compounds, e. g. conductive PTFE
- Valve plug and seat made of special material (e. g. HC4, tantalum, titanium, aluminium oxide) for erosive media
- Bellows and plug stem made of special material (e. g. Hastelloy)
- Other components made of special material
- Version for process media with intense permeation
- Version for process media that crystallize out
- Version for -40 °C

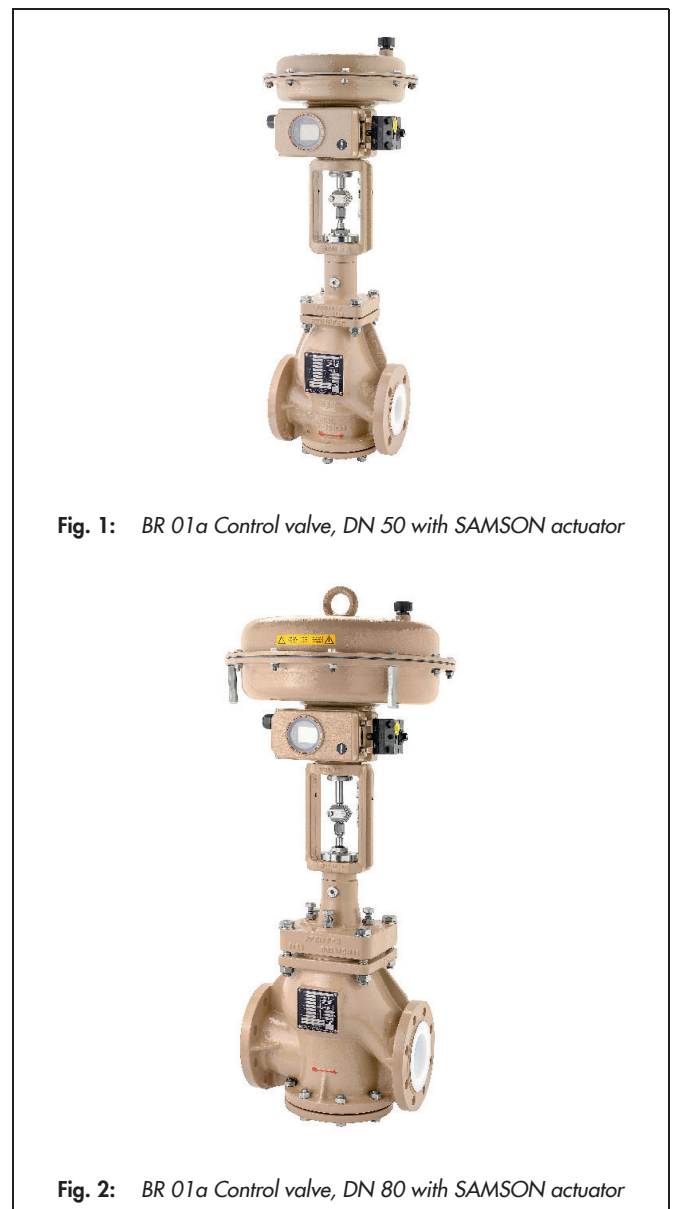
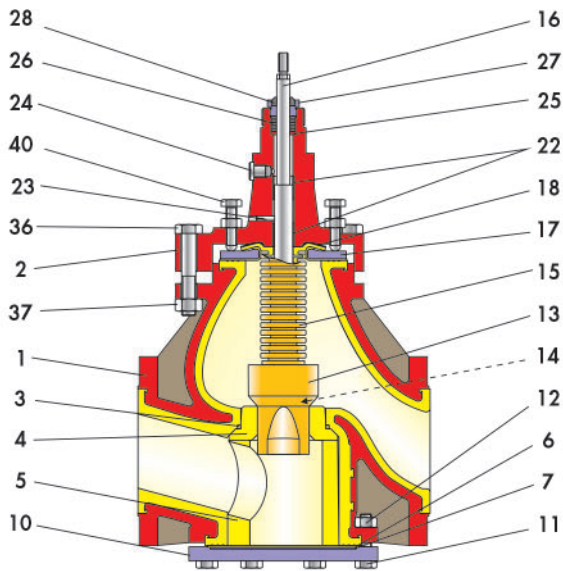
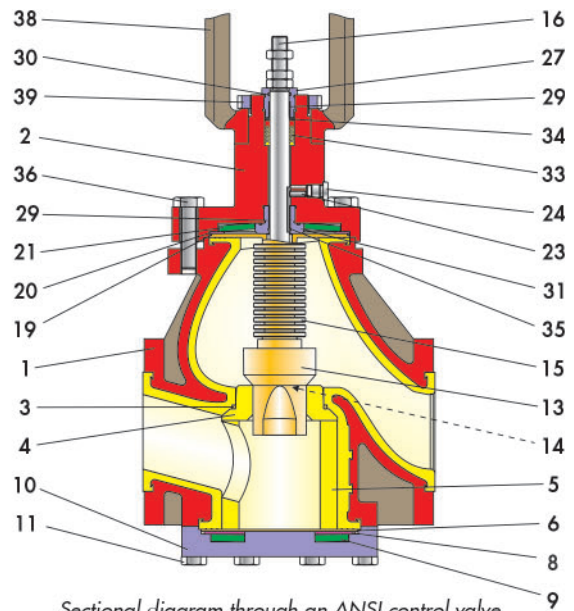

Fig. 1: BR 01a Control valve, DN 50 with SAMSON actuator

Fig. 2: BR 01a Control valve, DN 80 with SAMSON actuator



Sectional diagram through a DIN control valve
DN 80 to DN 150 / NPS4 and NPS6



Sectional diagram through an ANSI control valve
(up to NPS3)

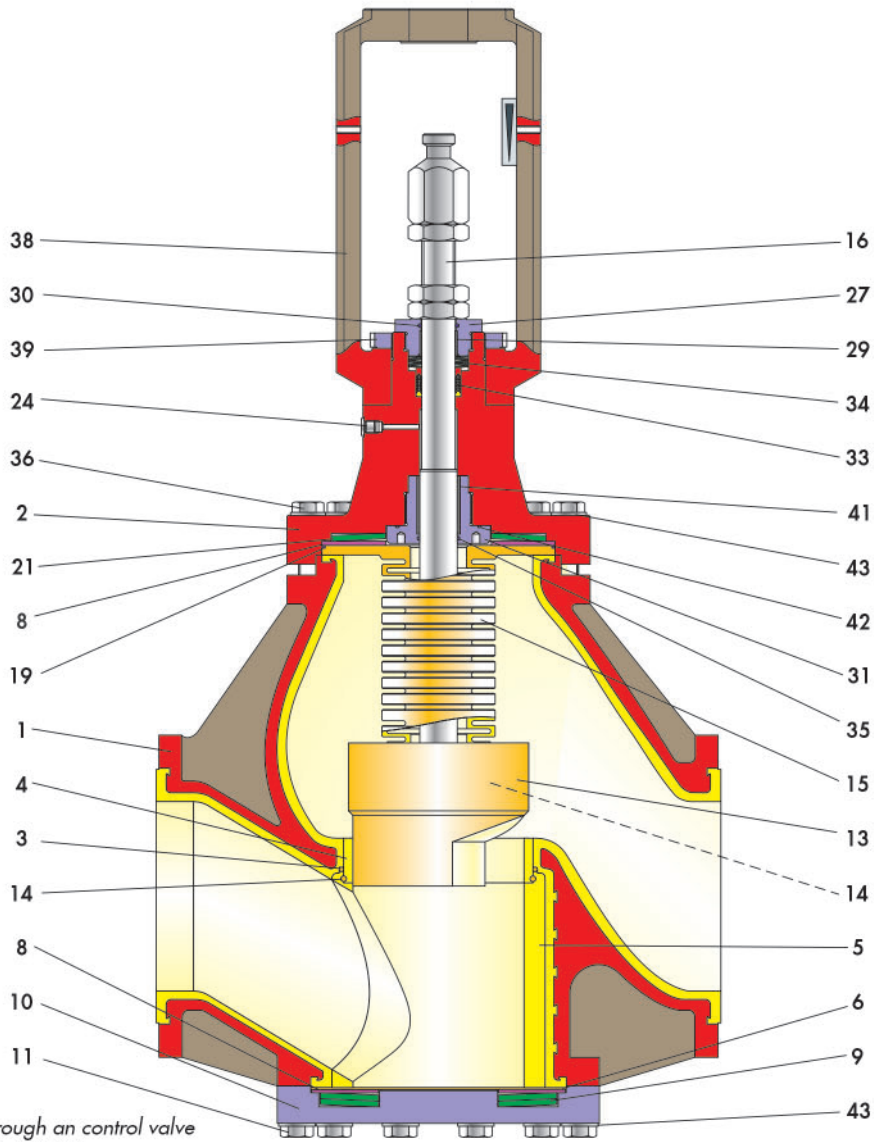

Sectional diagram through a control valve
(DN 200 / NPS8)

Fig. 3: Sectional diagram through a PFEIFFER BR 01a control valve

Further details and versions can be found in the mounting and operating instructions.

Table 1: List of parts

Item	Description
1	Valve body
2	Bonnet
3	O-ring
4	Seat
5	Thrust piece
6	Disc
7	Inlay
8	Thrust washer
9	Disc spring
10	Cover
11	Screw / Stud bolt
12	Nut
13	Plug
14	Cord
15	Bellows
16	Stem
17	Bead flange
18	Disc
19	O-ring
20	Thrust washer
21	Disc spring

Item	Description
22	Bush
23	Grooved pin
24	Screw plug
25	Washer
26	Packing
27	Stuffing box
28	Wiper ring
29	Bearing bush
30	O-ring
31	Guide bush
33	V-ring packing
34	Disc spring set
35	O-ring
36	Screw
37	Nut
38	Yoke
39	Lock nut
40	Screw
41	Bearing bush
42	O-ring
43	Washer

Principle of operation

The process medium flows through the globe valve in the flow-to-open direction. The valve plug position determines the cross-sectional area of flow between the seat (4) and the plug (13).

The plug is connected over the stem (16) to the actuator stem.

The PTFE bellows (15) seals the area between the valve body (1) and stem (16).

The PTFE/graphite packing or the PTFE V-ring packing (26) is used as a backup stem sealing. A test connection port (24) allows the bellows seal (15) to be monitored for leakage, e.g. by connecting a suction line or inert gas line.

The plug (13) is easily exchanged thanks to its tongue and groove connection to the PTFE bellows which is secured by a strong PTFE cord (14).

The cover (10) with inlay (7), PTFE disc (6) and PTFE thrust piece (5) fix the exchangeable PTFE seat (4) in position.

i Note

In the event that cavitation may occur, we recommend the use of a guided plug for differential pressures over 3 bar or a differential pressure ratio $p_2 < \Delta p$.

i Note

Before using the valve in hazardous areas, check whether this is possible according to ATEX 2014/34/EU by referring to the mounting and operating instructions ► EB 01a.

Fail-safe position

Depending on how the pneumatic actuator is mounted to the valve, the valve has two fail-safe positions which become effective when the air pressure in the actuator is relieved or when the supply air fails:

- **Fail-close valve [STAF]**

Upon air failure, the valve is closed. The valve opens when the signal pressure increases, acting against the force of the springs.

- **Fail-open valve [STEF]**

Upon air failure, the valve is opened. The valve closes when the signal pressure increases, acting against the force of the springs.

Additional equipment and add-on pieces

For the control valves, the following accessories are available either individually or in combination:

- Positioner
- Limit switch
- Solenoid valves
- Supply air pressure regulator/filter
- Pressure gauge mounting blocks
- Pneumatic volume booster

Further accessories are available on request for customer specifications

Table 2: General technical data

Nominal size	DIN		ANSI	
	DN 25 ... 200	NPS1 ... 4	NPS6	NPS8
Nominal pressure	PN 10/16	d150	d150 (FTF 480 mm)	d150 (FTF 600 mm)
Temperature range	See pressure-temperature diagram			
Characteristic	Equal percentage ¹⁾ / linear			
Leakage rate (soft seal)	Leakage rate A according to DIN EN 12266-1, P12			
Rangeability	20:1 (up to Kvs 0.1) / 50:1 (Kvs 0.25 and higher) / 30:1 (DN 80/NPS 3 and larger)			
End connections	DIN EN 1092-2, Form B	ANSI d150		

¹⁾ from kvs 0.1

Table 3: Materials

Nominal size	DIN		ANSI		
	DN 25 ... 150	DN 200	NPS1 ... 3	NPS4 ... 6	NPS8
Valve body	EN-JS 1049 (GGG 40.3)		ASTM A395		
Lining	PTFE, optionally conductive PTFE				
Bottom flange	EN-JS 1049 (GGG 40.3) or 1.0460		ASTM A395 or ASTM A105		
Plug and seat	PTFE ²⁾ , optionally special material				
Bellows	PTFE, optionally special material				
Retainer	PTFE				
Packing	Graphite packing	PTFE V-ring packing loaded by spring washers		Graphite packing	PTFE V-ring packing loaded by spring washers
Stem	Corrosion-resistant steel 1.4571				
Connecting elements	A2-70 / A4-70		A193-B7	A193-B7 (A2-70 / A4-70)	
Paint coating	Two-component polyurethane coat, grey beige, (RAL 1019)				

²⁾ Control insert in tantalum or other metals for 2 mm seat diameter

Pressure-temperature diagram

The range of application is determined by the pressure-temperature diagram. Process data and medium can affect the values of the diagram.

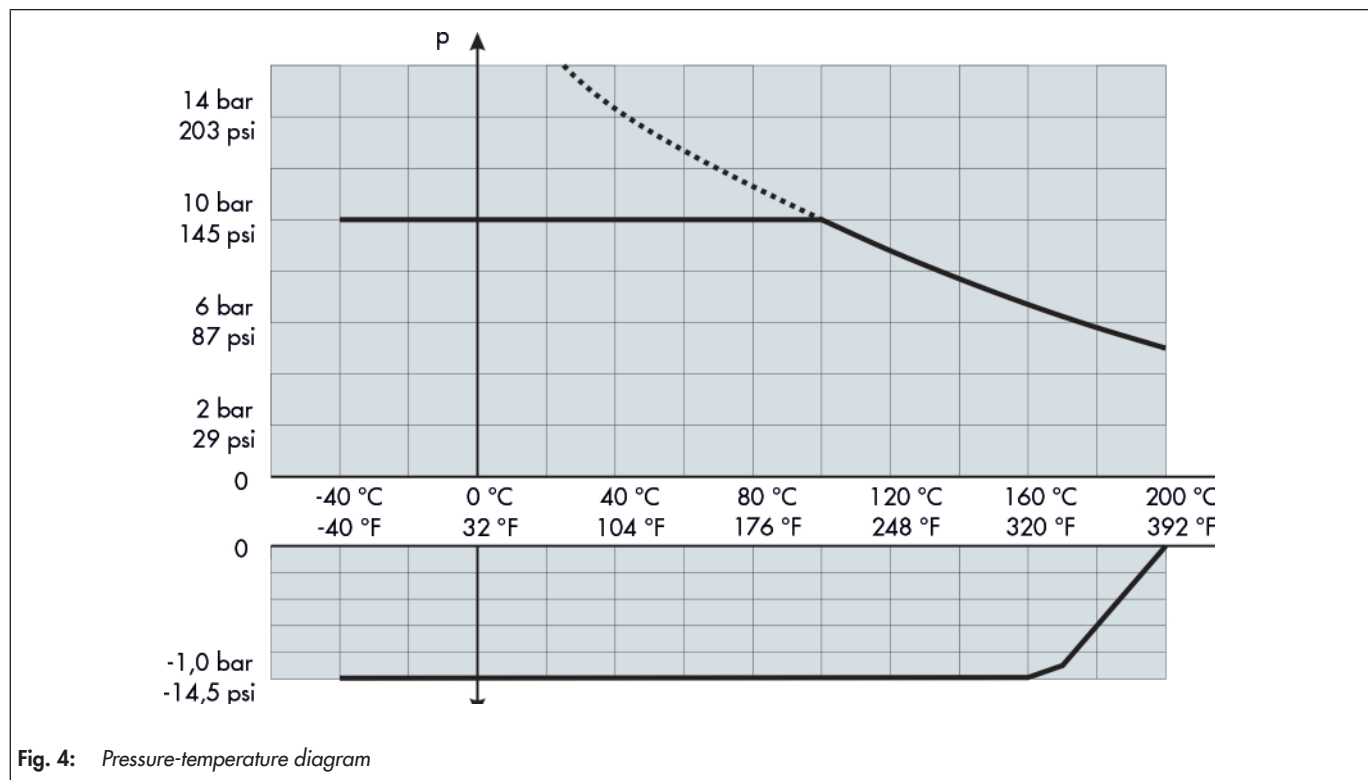

Fig. 4: Pressure-temperature diagram

Table 4: Permissible differential pressures Δp

The permissible differential pressures specified apply to soft-seated valves only.

Signal pressure range				Fail-close valve								Fail-open valve ¹⁾														
				0.2 ... 1.0	0.4 ... 2.0	0.5 ... 2.5	0.6 ... 3.0	0.9 ... 1.7	1.1 ... 2.4	1.3 ... 2.9	1.4 ... 2.3	1.9 ... 3.3	2.1 ... 3.3	0.2 ... 1.0												
Supply pressure in bar				Required supply pressure								Max. supply pressure														
				1.4	2.4	2.9	3.4	2.1	2.8	3.3	2.7	3.7	3.7	1.2	1.4	1.6	1.8	2.0	3.0							
DN	NPS	Seat \varnothing in mm	Actuator in cm ²	Δp when p2 = 0																						
25	1	2	120	8 ²⁾													8									
			175v2	16 ²⁾	16 ²⁾														16							
			240	16 ²⁾															16							
		6	120	8															8							
			175v2	16															16							
			240	16															16							
		13	120		8														8							
			175v2	3	16														3	16						
			240		16															16						
		24	120		4.5		8												4.5							
			175v2		4	7	10				16									9	16					
			240		9		16													16						
350	4		16														4	16								
40	1½	30	120		2.5		5.5											2.5	5.5							
			175v2		1	3	5			16																
			240		5		11												5	11						
			350		10		16												10	16						
			355v2		7		16												9	16						
50	2	38 / 40	120		1.5		3												3							
			175v2			1	2			11																
			240		3		6													6						
			350		5		11												5	11						
			355v2		3		8	16			16	16							5	10	16					
80	3	55	355v2	5 ³⁾	16 ³⁾			2	7			13	16						3	6	9					
			700		7		12												7	12						
			750v2			9								16					7	12						
80-100	3-4	65	355v2					4				9	13						2	4	6					
			700		4		8												4	8						
			750v2			6								16					4	8						
100	4	85	355v2									4	7									2	2			
			700				4													4						
			750v2				4							13						4						
			1400		5	7	10												5	10	14					
150	6	110	1400		4	6	8											5	8	12						
			700											7	10											
			750v2																	1						
120	700			3				6									2	5	7	10						
	1400				3							5	9					2	4	6	8					
200	8	181	1400						3	4 ⁵⁾										2	3					
			2800 ⁴⁾		2	3	4			9 ⁶⁾											6	8				

Table 4a: Valves with SAMSON actuator (fail-close)
Valve closed with 0 bar signal pressure

Table 4b: Valves with SAMSON actuator (fail-open)
Valve closed when required signal pressure is applied

¹⁾ We strongly recommend using an actuator with travel stop. On the other hand, the supply air must be safely limited.

²⁾ Actuator with travel stop

³⁾ At stroke 30 mm

⁴⁾ With stroke limitation to 60 mm

⁵⁾ 1.3 ... 2.8 bar

⁶⁾ 1.1 ... 2.3 bar

Table 5: z values depending on KVS coefficient, valve size and seat diameter

Nominal size		DN 25				DN 40	DN 50		DN 80		DN 100			DN 150		DN 200
		NPS1				NPS1½	NPS2		NPS3		NPS4			NPS6		NPS8
Seat-ø in mm ¹⁾		2	6	13	24	30	38	40	55	65	65	85	90	110	120	181
kvs	Cv	Acoustical valve coefficient z														
0.005 0.01 0.025 0.05 0.1	0.006 0.01 0.029 0.06 0.12	0.85														
0.25 0.63 1.0	0.29 0.74 1.17		0.65	0.65												
1.6 2.5	1.9 2.9			0.6												
4	4.7			0.55	0.55	0.55										
6.3	7.4				0.45	0.5	0.5									
10	12				0.4	0.45	0.45	0.45								
16	19					0.4	0.4		0.45							
21	24					0.35										
25	29						0.35		0.4		0.4			0.45		
35	41							0.35								
40	47								0.35		0.35			0.4		
63	74								0.3		0.3			0.35		
80	94									0.25	0.25			0.3		
100	117									0.25	0.25	0.25		0.3		
125	146										0.2					
150	175										0.2	0.2	0.2	0.2		
200	234															0.2
260	304													0.2		
300	351													0.2	0.2	
400	468															0.2
450	527															0.2

¹⁾ Linear characteristic only possible with 2 mm seat diameter

Terms for control valve sizing

According to IEC 60534-2-1:

$$FL = 0.95 \quad xT = 0.75$$

Correction terms

- For gases and vapors : $\Delta LG = 0$,
- For liquids: $\Delta LF = 0$

Table 6: *kvs* coefficient, travel and seat diameter of parabolic plugs and V-port plugs

Nominal size	DN 25				DN 40	DN 50		DN 80		DN 100			DN 150		DN 200			
	NPS1				NPS1½	NPS2		NPS3		NPS4			NPS6		NPS8			
Seat-ø in mm	2	6	13	24	30	38	40	55	65	65	85	90	110	120	181			
Travel in mm	10	15			30	15	30	15	30			50	60	30	50	30	50	60
	<i>kvs</i>	<i>Cv</i>																
0.005 0.01 0.025 0.05	0.006 0.01 0.029 0.06	P																
0.1	0.12	P	P															
0.16 0.25 0.4	0.19 0.29 0.47		P															
0.63 1.0	0.74 1.17		P	T														
1.6 2.5	1.9 2.9			P+T														
4	4.7		P	T	P+T													
6.3	7.4			P+T	P+T	P+T												
10	12			P+T	P+T	P+T	T ¹⁾											
16	19				P+T	P+T		P+T										
21	25					T												
25	29					P+T	T ¹⁾	P+T	P+T				T					
35	41						P+T											
40	47							P+T	P+T				P+T	T				
63	74							P+T	P+T				P+T	T				
80	94								P+T	P+T			P+T					
100	117								P	P	P+T	T		P+T	T			
125	146										P+T ²⁾	T						
150	175										P	T ²⁾	T ³⁾	P+T ²⁾	T			
200	234																	T
260	304															P	T	
300	351															P ³⁾	T ³⁾	T
400	468																	T
450	527																	T
500	585																	³⁾

P = Parabolic plug, T = V-port plug

¹⁾ Version in ceramic or special metal

²⁾ Linear only

³⁾ Contact PFEIFFER

Dimensions and weights

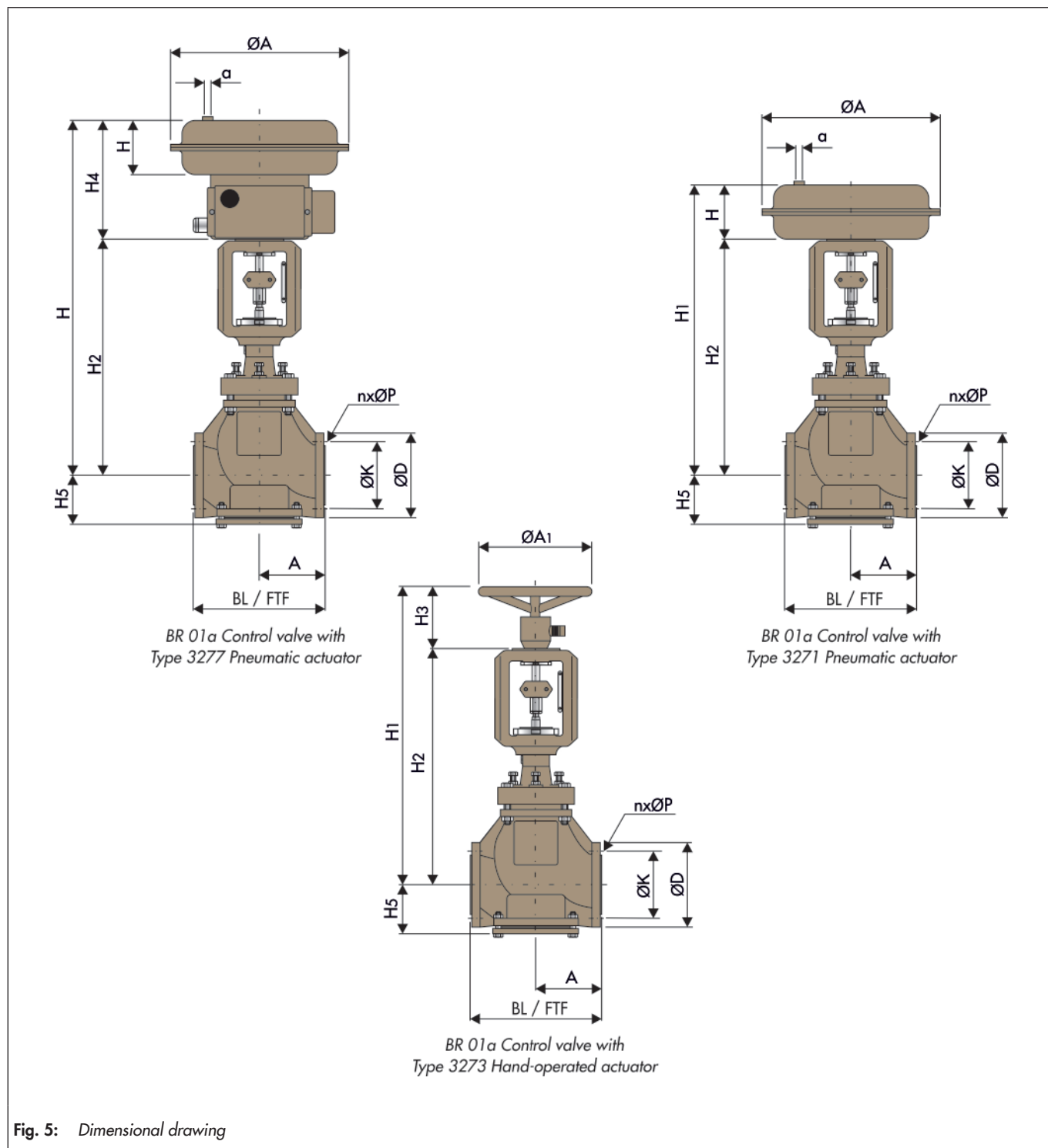

Fig. 5: Dimensional drawing

Table 7: Actuator dimensions in mm and weights in kg

Pneumatic actuator in cm ²	120	175v2	240	350	355v2	700	750v2	1400	2800
Diaphragm ØA	168	215	240	280	280	390	394	532	770
Height H	69 / 70	78	65	82	121	135	171	201	585
Height H4	158	179	166	183	222	236	272	-	
Signal pressure connection a	G ¹ / ₈ "	G ¹ / ₄ "		G ³ / ₈ "				G ³ / ₄ "	G1"
Weight of actuator Type 3271 in kg	2.5	6	5	8	15	22	36	70	450
Weight of actuator Type 3277 in kg	3.2	10	9	12	19	26	40	-	

Table 8: Valve dimensions in mm and weights in kg

Nominal size		DN 25	DN 40	DN 50	DN 80	DN 100	DN 150	DN 200	
BL	Basic series 1	160	200	230	310	350	480	600	
A	Basic series 1	80	100	115	155	179.5 / 170.5	240	300	
H1	Samson Type 3271	H2 + H							
	Samson Type 3277	H2 + H4							
	Samson Type 3273	H2 + H3						-	
H2	Actuator 120 cm ²	412	449	451					
	Actuator 240 ... 700 cm ²	425	462	464	526	705	719		
	Actuator 1400 cm ²					795	809	932	
	Actuator 2800 cm ²							auf Anfrage	
	H5	60	77	84	117	139	201	241.5	
	ØD	115	150	165	200	220	285	340	
	ØK	85	110	125	160	180	240	295	
	nxØP	4x14	4x18	4x18	8x18	8x18	8x22	8x22	
	Weight of valve in kg	14	18	21	45	90	145	275	
Actuator	120 cm ²	•	•	•					
	175v2 cm ²	•	•	•					
	240 cm ²	•	•	•					
	350 cm ²	•	•	•					
	355v2 cm ²		•	•	•	•			
	700 cm ²		•	•	•	•	•		
	750v2 cm ²		•	•	•	•	•		
	1400 cm ²					•	•	•	
2800 cm ²							•		
	ØA ₁	180	180	180	250	250	250	250	
	H ₃	110	110	110	115	115	115	115	
	Gewicht Typ 3273 in kg	2	2	2	2.5	2.5	-	-	

Nominal size		NPS1	NPS1½	NPS2	NPS3	NPS4	NPS6	NPS8	
FTF	Basic series 37	184	222	254	298	352	480 ¹⁾	600 ¹⁾	
A	Basic series 37	92	111	127	139.5 / 158.5	172.5	240	300	
H1	Samson Type 3271	H2 + H							
	Samson Type 3277	H2 + H4							
	Samson Type 3273	H2 + H3						-	
H2	Actuator 120 cm ²	353	392	390					
	Actuator 240 ... 700 cm ²	366	405	403	535	704.5	719		
	Actuator 1400 cm ²					794.5	809	934	
	Actuator 2800 cm ²							auf Anfrage	
	H ₅	72	82	95	128	147	201	241.5	
	ØD	108	127	152.4	190.5	228.6	279.4	343	
	ØK	79.4	98.4	120.6	152.4	190.5	241.3	298.5	
	nxØP	4x15.9	4x15.9	4x19	4x19.1	8x19.1	8x22.2	12x22.4	
	Weight of valve in kg	16	21	24	45	90	145	275	
Actuator	120 cm ²	•	•	•					
	175v2 cm ²	•	•	•					
	240 cm ²	•	•	•					
	350 cm ²	•	•	•					
	355v2 cm ²		•	•	•	•			
	700 cm ²		•	•	•	•	•		
	750v2 cm ²		•	•	•	•	•		
	1400 cm ²					•	•	•	
2800 cm ²							•		
	ØA ₁	180	180	180	250	250	250	250	
	H ₃	110	110	110	115	115	115	115	
	Gewicht Typ 3273 in kg	2	2	2	2.5	2.5	-	-	

¹⁾ Face-to-face dimension according to DIN (basic series 1)

Selection and sizing of the control valve

1. Calculate the appropriate Kvs coefficient according to IEC 60534
2. Select the valve size and Kvs coefficient from Table 6
3. Determine the differential pressure, select the appropriate actuator from Tables 4a and 4b.
4. Check the application based on the pressure-temperature diagram.
5. Additional equipment

Ordering text:

BR 01a Control Valve

Nominal size:

Nominal pressure:

Flow coefficient: kvs

Characteristic: equal percentage / linear

Body: EN-JS 1049/white PTFE

Flange design:

Special design:

Actuator: SAMSON Type cm²

Signal pressure range: bar

Fail-safe position:

Limit switch (brand name):

Solenoid valve (brand name):

Positioner (brand name):

Others:

Associated data sheets

- Associated installation and operating instructions ► EB 01a
- Associated safety manual ► SH 01
- For pneumatic actuator ► T8310-1 to T8310-3 (SAMSON)

i Note

All relevant details regarding the version ordered, which deviate from the specified version in this technical description data, can be taken, if required, from the corresponding order confirmation.
