

# MOUNTING AND OPERATING INSTRUCTIONS



## EB 2172 EN

Translation of original instructions



## Type 43-6 Temperature Regulator Self-operated Regulators

Edition July 2024



## Note on these mounting and operating instructions

These mounting and operating instructions assist you in mounting and operating the device safely. The instructions are binding for handling SAMSON devices. The images shown in these instructions are for illustration purposes only. The actual product may vary.

- For the safe and proper use of these instructions, read them carefully and keep them for later reference.
- If you have any questions about these instructions, contact SAMSON's After-sales Service (aftersalesservice@samsongroup.com).



The mounting and operating instructions for the devices are included in the scope of delivery. The latest documentation is available on our website at [www.samsongroup.com](http://www.samsongroup.com) > **Downloads** > **Documentation**.

## Definition of signal words

### **DANGER**

*Hazardous situations which, if not avoided, will result in death or serious injury*

### **WARNING**

*Hazardous situations which, if not avoided, could result in death or serious injury*

### **NOTICE**

*Property damage message or malfunction*

### **Note**

*Additional information*

### **Tip**

*Recommended action*

<b>1</b>	<b>Safety instructions and measures</b> .....	<b>1-1</b>
1.1	Notes on possible severe personal injury .....	1-5
1.2	Notes on possible personal injury .....	1-5
1.3	Notes on possible property damage .....	1-7
<b>2</b>	<b>Markings on the device</b> .....	<b>2-1</b>
2.1	Inscription on the valve .....	2-1
2.2	Inscription on the control thermostat .....	2-2
2.3	Location of inscriptions on the valve and control thermostat .....	2-2
2.4	Material identification number .....	2-3
<b>3</b>	<b>Design and principle of operation</b> .....	<b>3-1</b>
3.1	Additional fittings .....	3-3
3.2	Technical data .....	3-4
<b>4</b>	<b>Shipment and on-site transport</b> .....	<b>4-1</b>
4.1	Accepting the delivered goods .....	4-1
4.2	Removing the packaging from the regulator .....	4-1
4.3	Transporting and lifting the regulator .....	4-1
4.4	Storing the regulator .....	4-2
<b>5</b>	<b>Installation</b> .....	<b>5-1</b>
5.1	Installation conditions .....	5-1
5.2	Preparation for installation .....	5-3
5.3	Mounting .....	5-5
5.3.1	Installing the regulator .....	5-6
5.3.2	Cleaning the pipeline .....	5-6
5.4	Testing the regulator .....	5-6
5.4.1	Leak test .....	5-7
5.4.2	Pressure test .....	5-7
5.5	Insulation .....	5-8
<b>6</b>	<b>Start-up</b> .....	<b>6-1</b>
6.1	Start-up and putting the regulator back into operation .....	6-2
6.1.1	Starting up the plant when gases and liquids are controlled .....	6-2
6.1.2	Starting up the plant when vapors are controlled .....	6-2
<b>7</b>	<b>Operation</b> .....	<b>7-1</b>
7.1	Adjusting the temperature set point .....	7-1

## Contents

<b>8</b>	<b>Malfunctions .....</b>	<b>8-1</b>
8.1	Troubleshooting .....	8-1
8.2	Emergency action .....	8-3
<b>9</b>	<b>Servicing.....</b>	<b>9-1</b>
9.1	Service work preparations .....	9-4
9.2	Installing the regulator after service work .....	9-4
9.3	Service work.....	9-4
9.4	Cleaning and exchanging the seat and plug .....	9-4
9.5	Ordering spare parts and operating supplies .....	9-6
<b>10</b>	<b>Decommissioning .....</b>	<b>10-1</b>
<b>11</b>	<b>Removal .....</b>	<b>11-1</b>
11.1	Removing the control thermostat .....	11-1
11.2	Removing the valve from the pipeline.....	11-1
<b>12</b>	<b>Repairs .....</b>	<b>12-1</b>
12.1	Returning devices to SAMSON .....	12-1
<b>13</b>	<b>Disposal.....</b>	<b>13-1</b>
<b>14</b>	<b>Certificates.....</b>	<b>14-1</b>
<b>15</b>	<b>Appendix.....</b>	<b>15-1</b>
15.1	Tightening torques.....	15-1
15.2	Tools .....	15-1
15.3	Lubricants.....	15-1
15.4	Spare parts .....	15-2
15.5	After-sales service .....	15-3

# 1 Safety instructions and measures

## Intended use

The SAMSON Type 43-6 Regulator is a temperature regulator. It consists of a Type 2436 Valve and a Type 2430 Control Thermostat. The valve and control thermostat are delivered separately and must be assembled according to the instructions in these mounting and operating instructions.

The self-operated regulator is used to control the temperature in the plant to an adjusted set point. Liquids and gases or steam in district heating systems can be controlled by the Type 43-6 Regulator.

The regulator is designed to operate under exactly defined conditions (e.g. operating pressure, process medium, temperature). Therefore, operators must ensure that the regulator is only used in operating conditions that meet the specifications used for sizing the regulator at the ordering stage. In case operators intend to use the controllers in applications or conditions other than those specified, contact SAMSON.

SAMSON does not assume any liability for damage resulting from the failure to use the device for its intended purpose or for damage caused by external forces or any other external factors.

➔ Refer to the technical data and inscription on the device for limits and fields of application as well as possible uses.

## Reasonably foreseeable misuse

The regulator is not suitable for the following applications:

- Use outside the limits defined during sizing and by the technical data
- Use outside the limits defined by the additional fittings mounted on the regulator

Furthermore, the following activities do not comply with the intended use:

- Use of non-original spare parts
- Performing service and repair work not described

## Safety features

The Type 43-6 Temperature Regulator does not have any special safety features. When relieved of pressure, the regulator is closed by the force of the internal valve springs.

## Safety instructions and measures

### Qualifications of operating personnel

The regulator must be mounted, started up, serviced and repaired by fully trained and qualified personnel only; the accepted industry codes and practices must be observed. According to these mounting and operating instructions, trained personnel refers to individuals who are able to judge the work they are assigned to and recognize possible hazards due to their specialized training, their knowledge and experience as well as their knowledge of the applicable standards.

### Personal protective equipment

SAMSON recommends checking the hazards posed by the process medium being used (e.g. ► GESTIS (CLP) hazardous substances database). Depending on the process medium and/or the activity, the protective equipment required includes:

- Protective clothing, safety gloves and eye protection in applications with hot, cold and/or corrosive media
- Wear hearing protection when working near the valve. Follow the instructions given by the plant operator.
- Check with the plant operator for details on further protective equipment.

### Revisions and other modifications

Revisions, conversions or other modifications of the product are not authorized by SAMSON. They are performed at the user's own risk and may lead to safety hazards, for example. Furthermore, the product may no longer meet the requirements for its intended use.

### Warning against residual hazards

To avoid personal injury or property damage, plant operators and operating personnel must prevent hazards that could be caused in the regulator by the process medium, the operating pressure or by moving parts by taking appropriate precautions. Plant operators and operating personnel must observe all hazard statements, warnings and caution notes in these mounting and operating instructions.

Hazards resulting from the special working conditions at the installation site of the regulator must be identified in a risk assessment and prevented through the corresponding safety instructions drawn up by the operator.

SAMSON also recommends checking the hazards posed by the process medium being used (e.g. ► GESTIS (CLP) hazardous substances database).

- Observe safety measures for handling the device as well as fire prevention and explosion protection measures.

These mounting and operating instructions cover the standard version of the devices and the standard mounting parts. Components that differ to those described in this document can be added or removed. Refer to the mounting and operating instructions of the components not covered in this document for the safety instructions and measures that need to be observed.

### **Responsibilities of the operator**

Operators are responsible for proper use and compliance with the safety regulations.

Operators are obliged to provide these mounting and operating instructions as well as the referenced documents to the operating personnel and to instruct them in proper operation. Furthermore, operators must ensure that operating personnel or third parties are not exposed to any danger.

Operators are additionally responsible for ensuring that the limits for the product defined in the technical data are observed. This also applies to the start-up and shutdown procedures. Start-up and shutdown procedures fall within the scope of the operator's duties and, as such, are not part of these mounting and operating instructions. SAMSON is unable to make any statements about these procedures since the operative details (e.g. differential pressures and temperatures) vary in each individual case and are only known to the operator.

### **Responsibilities of operating personnel**

Operating personnel must read and understand these mounting and operating instructions as well as the referenced documents and observe the specified hazard statements, warnings and caution notes. Furthermore, operating personnel must be familiar with the applicable health, safety and accident prevention regulations and comply with them.

### **Referenced standards, directives and regulations**

The regulators comply with the requirements of the European Pressure Equipment Directive 2014/68/EU. Regulators with a CE marking have an EU declaration of conformity, which includes information about the applied conformity assessment procedure. The EU declaration of conformity is included in the 'Certificates' chapter.

According to the ignition hazard assessment performed in accordance with Clause 5.2 of ISO 80079-36, the non-electrical regulators do not have their own potential ignition source even in the rare incident of an operating fault. As a result, they do not fall within the scope of Directive 2014/34/EU.

→ For connection to the equipotential bonding system, observe the requirements specified in Clause 6.4 of EN 60079-14 (VDE 0165-1).

## Safety instructions and measures

### Referenced documents

The following documents apply in addition to these mounting and operating instructions:

- Mounting and operating instructions for
    - e.g. **Type 2430 Control Thermostat** ▶ EB 2430

---
  - e.g. **Type 2403 Safety Temperature Monitor (STM)** ▶ EB 2183

---

  - e.g. **Type 2439 Safety Temperature Limiter (STL)** ▶ EB 2185

---

  - e.g. **Type 1 NI Strainer** ▶ EB 1010

---

  - e.g. **Type 2 NI Strainer** ▶ EB 1015
- 
- Data sheets for
  - e.g. **Accessories: Double adapter · Manual adjuster · Intermediate insulating piece** ▶ T 2176

---
- e.g. **Typetested safety devices** ▶ T 2181
- 
- e.g. **Type 2403 Safety Temperature Monitor (STM)** ▶ T 2183
- 
- e.g. **Type 2439 Safety Temperature Limiter (STL)** ▶ T 2185
- 
- e.g. **Type 1 NI Strainer** ▶ T 1010
- 
- e.g. **Type 2 NI Strainer** ▶ T 1015
- 
- Mounting and operating instructions as well as data sheets for additional fittings (e.g. shut-off valves, pressure gauges etc.).



## 1.1 Notes on possible severe personal injury

### DANGER

#### **Risk of bursting in the regulator.**

Regulators and pipelines are pressure equipment. Impermissible pressure or improper opening can lead to regulator components bursting.

- Observe the maximum permissible pressure for regulator and plant.
- Before starting any work on the regulator, depressurize all plant sections affected as well as the regulator.
- Drain the process medium from the plant sections affected as well as from the regulator.

## 1.2 Notes on possible personal injury

### WARNING

#### **Damage to health relating to the REACH regulation.**

If a SAMSON device contains a substance listed as a substance of very high concern on the candidate list of the REACH regulation, this is indicated on the SAMSON delivery note.

- Information on the safe use of the part affected. ► <https://www.samsongroup.com/en/about-samson/environment-social-governance/material-compliance/reach-regulation/>

#### **Risk of personal injury due to incorrect operation, use or installation as a result of information on the regulator being illegible.**

Over time, markings, labels and nameplates on the regulator may become covered with dirt or become illegible in some other way. As a result, hazards may go unnoticed and the necessary instructions not followed. There is a risk of personal injury.

- Keep all relevant markings and inscriptions on the device in a constantly legible state.
- Immediately renew damaged, missing or incorrect nameplates or labels.

## 1.2 Notes on possible personal injury

### WARNING

#### **Risk of burn injuries due to hot or cold components and pipelines.**

Depending on the process medium, regulator components and pipelines may get very hot or cold and cause burn injuries.

- Allow components and pipelines to cool down or warm up to the ambient temperature.
- Wear protective clothing and safety gloves.

#### **Risk of hearing loss or deafness due to loud noise.**

The noise emissions depend on the valve version, plant facilities and process medium.

- Wear hearing protection when working near the valve. Follow the instructions given by the plant operator.

#### **Risk of personal injury due to residual process medium in the regulator.**

While working on the regulator, residual process medium can escape and, depending on its properties, may lead to personal injury, e.g. (chemical) burns.

- If possible, drain the process medium from the plant sections affected and from the regulator.
- Wear protective clothing, safety gloves and eye protection.

## 1.3 Notes on possible property damage

### **Risk of regulator damage due to incorrectly attached slings.**

- Do not attach load-bearing slings to the regulator.

### **Risk of regulator damage due to unsuitable medium properties.**

The regulator is designed for a process medium with defined properties.

- Only use the process medium specified for sizing the equipment.

### **Risk of regulator damage due to contamination (e.g. solid particles) in the pipeline.**

The plant operator is responsible for cleaning the pipelines in the plant.

- Flush the pipelines before start-up.

### **Risk of regulator damage due to the use of unsuitable lubricants.**

The lubricants to be used depend on the regulator material. Unsuitable lubricants may corrode and damage surfaces.

- Only use lubricants approved by SAMSON.  
When in doubt, consult SAMSON.

### **Risk of leakage and regulator damage due to over- or under-torquing.**

Observe the specified torques when tightening regulator components. Excessive tightening torques lead to parts wearing out more quickly. Parts that are too loose may cause leakage.

- Observe the specified tightening torques (see the 'Tightening torques' chapter in the Appendix).

### **Risk of excess pressure damaging plant sections due to construction-related seat leakage through the regulator.**

- Always install a safety device (e.g. safety excess pressure valve or safety relief valve) in the plant.

### **Risk of regulator damage due to the use of unsuitable tools.**

Certain tools are required to work on the regulator.

- Only use tools approved by SAMSON.  
When in doubt, consult SAMSON.

### **Risk of the process medium being contaminated through the use of unsuitable lubricants and/or contaminated tools and components.**

- Keep the regulator and the tools used free from solvents and grease.
- Make sure that only suitable lubricants are used.

### **Incorrect control due to the formation of ice on the regulator.**

Medium temperatures below 0 °C may cause ice to form on the regulator, depending on the air humidity. This may affect, in particular, the functioning of the plug or control thermostat stem guide.

- Prevent the formation of ice by taking appropriate precautions (e.g. enclosure, trace heater etc.). The plant operator is responsible for selecting and implementing appropriate precautions (see the 'Installation' chapter).

### **Risk of irreparable regulator damage caused by the regulator components being taken apart.**

The control thermostat is an inseparable hydraulic unit consisting of a control thermostat, capillary tube and temperature sensor. If these components are dismantled (e.g. removal of the capillary tube), the regulator will be irreparably damaged and will no longer be able to fulfill its control task.

- Do not dismantle the regulator.
- Only perform allowed activities on the regulator.
- Contact SAMSON's After-sales Service before replacing spare parts.

---

#### **i Note**

*SAMSON's After-sales Service can support you concerning lubricant, tightening torques and tools approved by SAMSON.*

---

## 2 Markings on the device

There are several inscriptions on the device. The inscriptions are used to identify the separate regulator components (see Fig. 2-1 and Fig. 2-2).

The inscription shown was up to date at the time of publication of this document. The inscription on the device may differ from the one shown.

### 2.1 Inscription on the valve

#### Inscription on bodies made of red brass or spheroidal graphite iron

SAMSON		1
2	3	4
5		6
		7

- 1 Type designation
- 2 Model number
- 3 Material number and device index
- 4 Order number or year of manufacture
- 5  $K_{VS}/C_V$
- 6 Perm. temperature in °C/°F
- 7 Perm. temperature in °C/°F

Nominal size, pressure rating and the arrow indicating the direction of flow are cast into the valve body.

#### Inscription on stainless steel body

	10	
SAMSON		1
2	3	4
5	8	6
9		7

- 1 Type designation
- 2 Model number
- 3 Material number and device index
- 4 Order number or year of manufacture
- 5 Flow coefficient:  
DIN:  $K_{VS}$  · ANSI:  $C_V$  · JIS:  $C_V$
- 6 Perm. temperature:  
DIN: °C · ANSI: °F · JIS: °C/°F
- 7 Max. perm. differential pressure  $\Delta p$ :  
DIN: bar · ANSI: psi · JIS: bar/psi
- 8 Thread size/nominal size:  
DIN: DN · ANSI: NPS · JIS: DN ... A/B
- 9 Pressure rating:  
DIN: PN · ANSI: CL · JIS: K
- 10 Arrow indicating the direction of flow

Fig. 2-1: *Inscription on the valve*

## 2.2 Inscription on the control thermostat

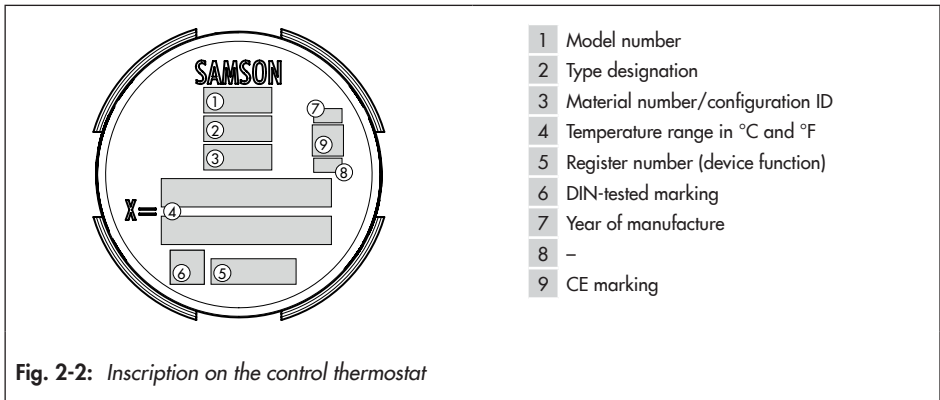

Fig. 2-2: Inscription on the control thermostat

## 2.3 Location of inscriptions on the valve and control thermostat

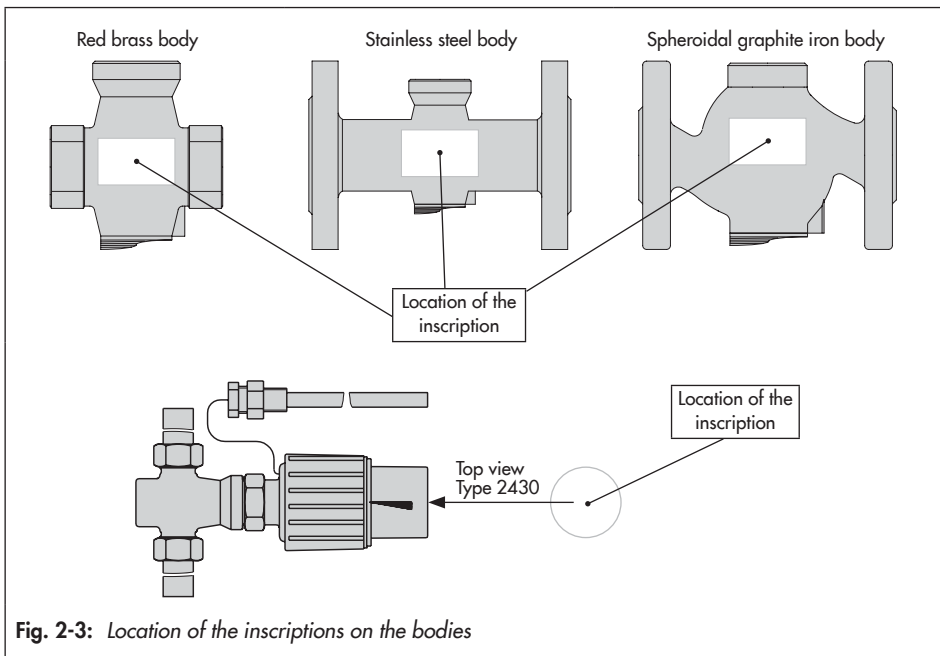

Fig. 2-3: Location of the inscriptions on the bodies

## 2.4 Material identification number

The material is indicated on the body. Specifying the material number, you can contact us to find out more details. The material number is included in the inscription ("Material number and device index", item 3).

For more details on the inscription, see Chapters 2.2 and 2.1.

## Markings on the device



### 3 Design and principle of operation

→ See Fig. 3-1

The regulator consists of a Type 2436 Globe Valve and a Type 2430 Control Thermostat with set point adjuster, a capillary tube and temperature sensor.

A temperature sensor operating according to the adsorption principle is used as standard.

---

#### **i Note**

*Details on the Type 2430 Control Thermostat with a temperature sensor operating according to the vapor pressure principle can be found in the mounting and operating instructions ▶ EB 2430.*

---

The valve bodies are made of red brass, spheroidal graphite iron or stainless steel.

The Type 2430 Control Thermostat is attached to the valve body (3) using the coupling nut (40).

The temperature regulators work according to the adsorption principle. The temperature of the medium creates a pressure in the sensor (48) which is proportional to the measured temperature. This pressure is transferred through the capillary tube (47) to the operating element (46) and converted into a positioning force. This force causes the pin of the operating element (45) to move the plug stem (1.2) with the plug (1). The plug is pressure-balanced (1.1).

By turning the set point adjuster (43), the point of response is changed over the valve

spring (22). As a result, the temperature set point is changed.

The regulator is suited for plants to be cooled.

The valve opens when the temperature rises.

#### **Version with safety thermostat**

When a Type 2439 or Type 2403 Safety Thermostat is attached to the valve or the regulator, this combination functions as a safety temperature limiter (TR/STL) or a safety temperature monitor (TR/STM).

Details in mounting and operating instructions

▶ EB 2185 (STL); ▶ EB 2083 (STM).

#### **Version with double adapter**

The temperature regulator can be equipped with a double adapter to connect an additional control thermostat to control a further control variable.

See Data Sheet ▶ T 2176.

#### **Version with handwheel**

For the manual operation of the valve. The manual adjuster can either be attached directly to the valve or at the double adapter instead of a control thermostat.

See Data Sheet ▶ T 2176.

---

#### **i Note**

*The Type 43-6 Regulator is not a safety valve. If necessary, a suitable overpressure protection must be installed on site in the plant section.*

---

## Design and principle of operation

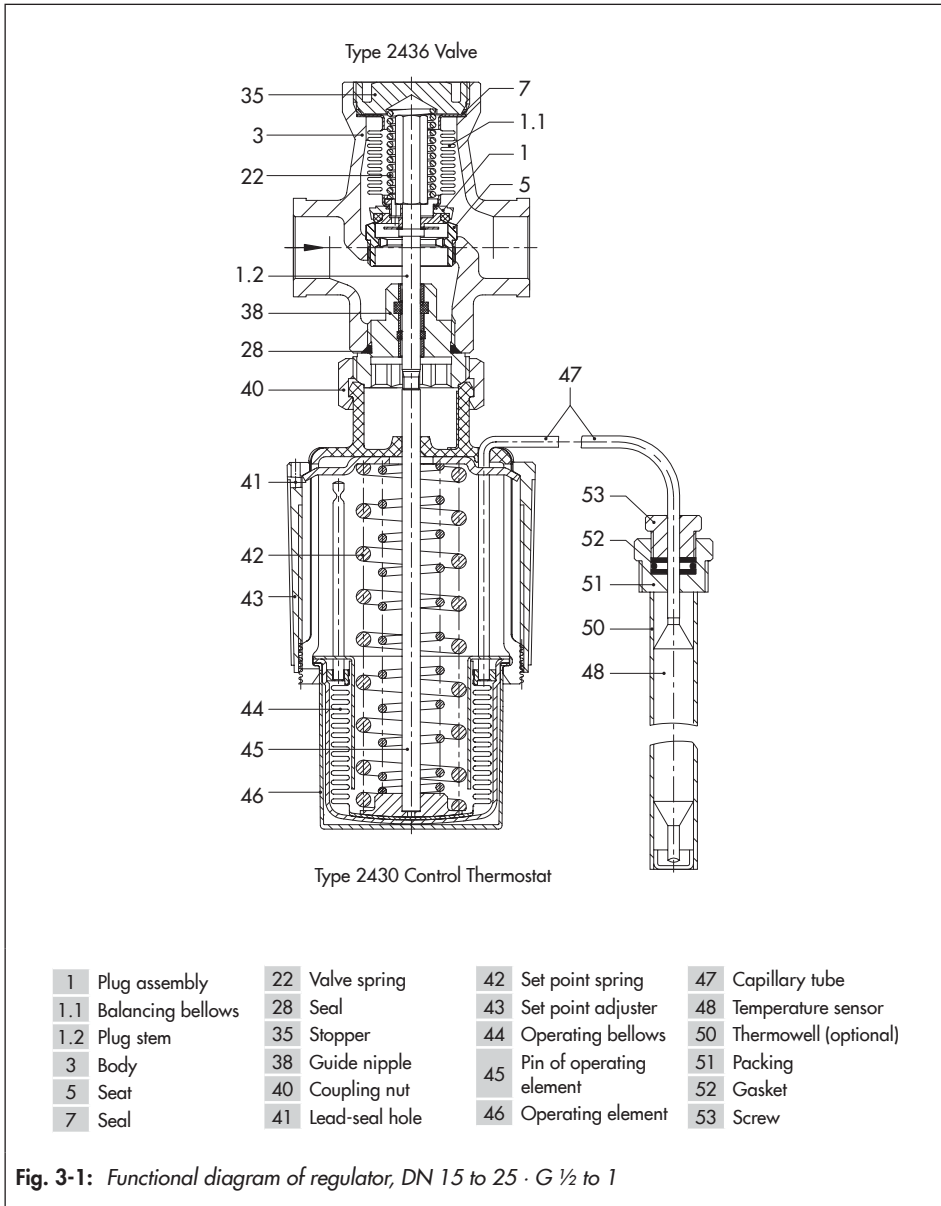

**Fig. 3-1:** Functional diagram of regulator, DN 15 to 25 · G ½ to 1

### 3.1 Additional fittings

→ See Fig. 3-2

#### Strainers

SAMSON recommends installing a SAMSON strainer (2) upstream of the valve. It prevents solid particles in the process medium from damaging the regulator.

- Do not use the strainer to permanently filter the process medium.
- Select a strainer (mesh size) suitable for the process medium.

#### **i** Note

Any impurities carried along by the process medium may impair the proper functioning of the regulator. We recommend installing a strainer (e.g. SAMSON Type 1 NI) upstream of the temperature regulator (► EB 1010).

#### Thermometer

Install a thermometer (4) downstream of the regulator to monitor the temperature prevailing in the plant.

#### Bypass and shut-off valves

SAMSON recommends installing a shut-off valve (1 and 6) both upstream of the strainer and downstream of the regulator and installing a bypass line. The bypass ensures that the plant does not need to be shut down for service and repair work on the regulator.

#### Insulation

Regulators can be insulated to reduce heat energy transfer.

Refer to the instructions in the 'Installation' chapter.

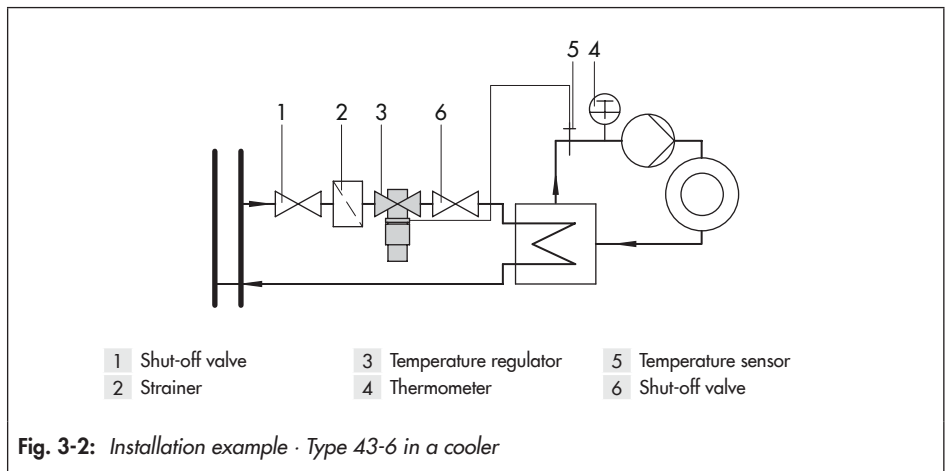

Fig. 3-2: Installation example · Type 43-6 in a cooler

### 3.2 Technical data

The regulator inscription provides information on the regulator version (see the 'Markings on the device' chapter).

#### **i Note**

More information is available in Data Sheets  
▶ T 2171 and ▶ T 2172.

#### **Process medium and scope of application**

Temperature regulators for district heating systems, heat generators, heat exchangers and other HVAC and industrial applications. The Type 43-6 Temperature Regulator is designed to maintain the temperature at the control thermostat sensor to the adjusted set point.

- Suitable for **liquids, gases and steam**
- Max. temperature up to **150 °C/300 °F**
- Temperature set points **from 0 to 150 °C/32 to 300 °F**
- Nominal sizes **G ½ to 1 ½ NPT to 1 NPT and DN 15 to 50**
- Pressure ratings **PN 25/Class 150 and 300/JIS 20K**

The regulator **opens** when the temperature rises.

#### **Conformity**

The Type 43-6 Regulator bears both the CE and EAC marks of conformity.

CE

EAC



#### **Testing according to DIN EN**

The **Type 43-6 Temperature Regulator** is tested by the German technical surveillance association TÜV according to DIN EN 14597 under the type designation 2750-0. The registration number is available on request.

#### **Noise emissions**

SAMSON is unable to make general statements about noise emissions. The noise emissions depend on the regulator version, plant facilities, process medium and operating conditions.

#### **Leakage class**

The metal-seated regulator has the leakage class I according to IEC 60534-4.

The soft-seated regulator has the leakage class IV according to IEC 60534-4.



#### **Temperature range**

Depending on how the Type 43-6 Regulator is configured, it can be used up to max. 150 °C/300 °F. The minimum temperature is limited by the seal material used in the regulator (see Table 3-1).

#### **Dimensions and weights**

Table 3-4 provides a summary of the dimensions and weights. The lengths and heights in the dimensional drawings are shown on page 3-9.

**Table 3-1: Technical data · All pressures in bar (gauge)**

Type 2436 Valve				
Nominal size	ANSI		DIN	
	½ NPT to 1 NPT		G ½ to 1	DN 15 to 25
Pressure rating	Class 150		PN 25	
Max. permissible differential pressure $\Delta p$	232 psi		16 bar	8 bar
Perm. permissible temperature range of valve <sup>4)</sup>	32 to 302 °F		0 to 150 °C	
Leakage class according to IEC 60534-4	Metal seal: Leakage class I ( $\leq 0.05$ % of $K_{VS}/C_V$ coefficient) Soft seal: Leakage class IV ( $\leq 0.01$ % of $K_{VS}/C_V$ coefficient)			
Conformity				
Type 2430 Control Thermostat				
Set point range <sup>1)</sup> (continuously adjustable)	DIN	0 to 35 °C · 25 to 70 °C · 40 to 100 °C 50 to 120 °C · 70 to 150 °C		
	ANSI	32 to 95 °F · 77 to 158 °F · 104 to 212 °F 122 to 248 °F · 158 to 302 °F		
Capillary tube	6.56 ft · 16.4 ft <sup>3)</sup>		2 m · 5 m <sup>3)</sup>	
Max. perm. temperature at the sensor	50 K above the adjusted set point			
Permissible ambient temperature range	-4 to +176 °F <sup>2)</sup>		-20 to +80 °C <sup>2)</sup>	
Perm. pressure at sensor	Class 150		PN 25	
Permissible pressure at thermowell	Class 300 or 600 <sup>3)</sup>		PN 40 or 100 <sup>3)</sup>	
Conformity				

<sup>1)</sup> Further set point ranges on request

<sup>2)</sup> At temperatures below freezing: ice formation may damage the plant and especially the valve

<sup>3)</sup> Special version

<sup>4)</sup> With intermediate insulating piece -15 to 150 °C/5 to 302 °F

## Design and principle of operation

**Table 3-2:  $K_{VS}/C_V$  coefficients**

Type 2436 Valves						
	G 1/2 <sup>2) 4)</sup>	G 3/4 <sup>2) 4)</sup>	G 1 <sup>2) 4)</sup>			
$K_{VS}$ <sup>1)</sup>	3.2	4.0	5.0	-		
$C_V$ <sup>1)</sup>	4.3	6.8	8.6			
	DN 15 <sup>3)</sup>	DN 20 <sup>3)</sup>	DN 25 <sup>3)</sup>	DN 32 <sup>3)</sup>	DN 40 <sup>3)</sup>	DN 50 <sup>3)</sup>
$K_{VS}$ <sup>1)</sup>	3.2	4.0	5.0	12.5	16.0	20.0
$C_V$ <sup>1)</sup>	4.3	6.8	8.6	4.3	6.8	8.6

1) Special version with  $K_{VS}$  0.4, 1 or 2.5/ $C_V$  0.5, 1.2 or 3

2) Red brass body with screwed ends

3) Flanged body made of spheroidal graphite iron

4) Stainless steel body with screwed ends

**Table 3-3: Materials · Material numbers according to DIN EN**

Type 2436 Valve			
Body	DIN		DIN <sup>4)</sup> /ANSI <sup>5)</sup>
		Red brass (RG5) CC499K	Spheroidal graphite iron EN-GJS-400-18-LT <sup>1)</sup>
Seat	Stainless steel 1.4305		1.4408
Plug	Brass, resistant to dezincification, CW617N (CuZn40Pb) and 1.4104 with PTFE soft seal <sup>2) 3)</sup>		
Balancing bellows	Stainless steel 1.4571		
Valve spring	Stainless steel 1.4310		
Type 2430 Control Thermostat			
Set point adjuster	PTFE, glass fiber reinforced		
Temperature sensor	Capillary tube	Copper	
	Thermowell	Copper or stainless steel 1.4310	

1) Flanged body valve (DIN only)

2) For oils (ASTM I, II, III): FKM soft seal

3) When  $K_{VS} = 0.4$  and 1.0: 1.4305

4) Female thread (G 1/2 to G 1) and flanges (DN 15 and 25)

5) Female thread (1/2 NPT to 1 NPT)

**Table 3-4:** Dimensions in mm and weights in kg

<b>Type 2436 Valve (female thread)</b>						
Nominal size	DIN			ANSI		
	G ½	G ¾	G 1	½ NPT	¾ NPT	1 NPT
Length L	65 mm	75 mm	90 mm	2.56 inch	2.95 inch	3.54 inch
Height H	190 mm			7.5 inch		
Height H2	46 mm			1.8 inch		
Width across flats (A/F)	34		46	34		46
<b>Weight</b>						
Type 43-6 with bulb sensor and thermowell <sup>1) 2)</sup> (approx.)	1.8 kg	1.9 kg	2.0 kg	4.0 lbs	4.2 lbs	4.4 lbs
<b>Type 2436 Valve (male thread)</b>						
Nominal size	DN 15	DN 20	DN 25	DN 32	DN 40	DN 50
Length L	65	70	75	100	110	130
Height H2	95					
Connection R	G ¾	G 1	G 1¼	G 1¾	G 2	G 2½
Width across flats (A/F)	30	36	46	59	65	82
Pipe Ø d	21.3	26.8	32.7	42.0	48.0	60.0
Male thread A	G ½	G ¾	G 1	G 1¼	G 1½	G 2
<b>Type 2436 Valve · Welding ends · Threaded ends</b>						
Length L1 for welding ends	210	234	244	268	294	330
Length L2 for threaded ends	129	144	159	180	196	228
Height H	210					
<b>Weight</b>						
Type 43-6 with bulb sensor and thermowell <sup>1)</sup> (approx. kg)	2.0	2.3	2.8	4.7	5.1	7.5
<b>Type 2436 Valves (flanges)</b>						
Nominal size	DN 15	DN 20	DN 25	DN 32	DN 40	DN 50
Length L3	130	150	160	180	200	230
Height H	180			230		

<sup>1)</sup> Version without thermowell: minus 0.2 kg

<sup>2)</sup> Stainless steel body +0.2 kg

## Design and principle of operation

**Table 3-4:** Dimensions in mm and weights in kg

Height H2	31			45		47
<b>Weight</b>						
Type 43-6 with bulb sensor and thermowell <sup>1)</sup> (approx. kg)	3.1	3.9	4.6	7.6	9.8	14.1
<b>Type 2430 Control Thermostat</b>						
	<b>DIN</b>			<b>ANSI</b>		
For nominal size	DN 15 to 25		DN 32 to 50		½ NPT to 1 NPT	
Screw gland S	G ½		G ¾		½ NPT	
Length L <sub>FT</sub>	185 mm		220 mm		7.28 inch	
Ø d <sub>F</sub>	9.5 mm		16 mm		0.37 inch	
Ø d <sub>T</sub>	12 mm		19 mm		0.47 inch	

<sup>1)</sup> Version without thermowell: minus 0.2 kg

<sup>2)</sup> Stainless steel body +0.2 kg



Dimensional drawings

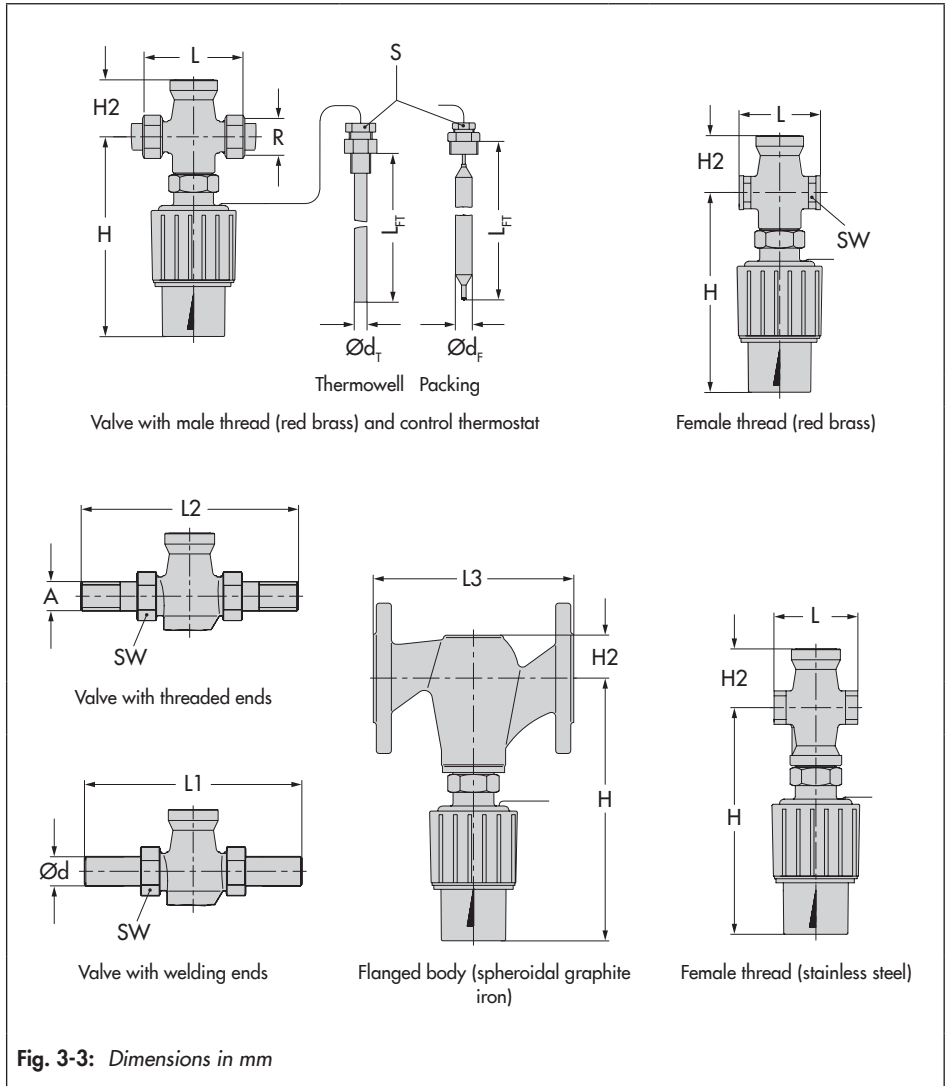



## 4 Shipment and on-site transport

The work described in this chapter is only to be performed by personnel appropriately qualified to carry out such tasks.

### 4.1 Accepting the delivered goods

After receiving the shipment, proceed as follows:

1. Check the scope of delivery. Check that the specifications on the nameplate and on the regulator itself match the specifications in the delivery note. See the 'Markings on the device' chapter for nameplate details.
2. Check the shipment for transportation damage. Report any damage to SAMSON and the forwarding agent (refer to delivery note).
3. Determine the weight and dimensions of the units to be lifted and transported in order to select the appropriate lifting equipment and lifting accessories. Refer to the transport documents and the 'Design and principle of operation' chapter.

### 4.2 Removing the packaging from the regulator

The components (valve, control thermostat and, if applicable, thermowell) of the regulator are delivered separately.

- Do not open or remove the packaging until immediately before lifting to install the regulator into the pipeline.
- Leave the regulator in its transport container or on the pallet to transport it on site.
- Do not remove the protective caps from the inlet and outlet until immediately before installing the valve with flanges into the pipeline. They prevent foreign particles from entering the valve.
- Dispose and recycle the packaging in accordance with the local regulations.

### 4.3 Transporting and lifting the regulator

Due to the low service weight, lifting equipment is not required to lift and transport the regulator (e.g. to install it into the pipeline).

- Leave the regulator in its transport container or on the pallet to transport it.
- Observe the transport instructions.

#### Transport instructions

- Protect the regulator against external influences (e.g. impact).
- Do not damage the corrosion protection (paint, surface coatings). Repair any damage immediately.
- Protect the regulator against moisture and dirt.
- The permissible ambient temperature of standard regulators is  $-20$  to  $+80$  °C/ $-4$  to  $+175$  °F.

## 4.4 Storing the regulator

---

### **NOTICE**

**Risk of regulator damage due to improper storage.**

- Observe the storage instructions.
- Avoid long storage times.
- Contact SAMSON in case of different storage conditions or longer storage times.

---

### Storage instructions

- Protect the regulator against external influences (e.g. impact).
- Secure the regulator in the stored position against slipping or tipping over.
- Do not damage the corrosion protection (paint, surface coatings). Repair any damage immediately.
- Protect the regulator against moisture and dirt. Store it at a relative humidity of less than 75 %. In damp spaces, prevent condensation. If necessary, use a drying agent or heating.
- Make sure that the ambient air is free of acids or other corrosive media.
- The permissible storage temperature of standard regulators is  $-20$  to  $+65$  °C/ $-4$  to  $+150$  °F.
- Do not place any objects on the regulator.

---

### **Note**

We recommend regularly checking the regulator and the prevailing storage conditions during long storage periods.

---

### Special storage instructions for elastomers

Elastomer, e.g. O-rings

- We recommend a storage temperature of  $15$  °C/ $60$  °F for elastomers.
- Store elastomers away from lubricants, chemicals, solutions and fuels.

---

### **Tip**

SAMSON's After-sales Service can provide more detailed storage instructions on request.

---

## 5 Installation

The work described in this chapter is only to be performed by personnel appropriately qualified to carry out such tasks.

Valve and control thermostat can be assembled before or after the valve has been installed in the pipeline. We recommend first installing the valve without the control thermostat into the pipeline.

### 5.1 Installation conditions

#### Work position

The work position for the regulator is the front view onto all operating controls on the regulator (including any additional fittings) seen from the position of operating personnel.

Plant operators must ensure that, after installation of the device, the operating personnel can perform all necessary work safely and easily access the device from the work position.

#### Pipeline routing

The inlet and outlet lengths vary depending on several variables and process conditions and are intended as recommendations. Contact SAMSON if the lengths are significantly shorter than the recommended lengths.

To ensure that the regulator functions properly, proceed as follows:

- ➔ Observe the inlet and outlet lengths (see Table 5-2). Contact SAMSON if the regulator conditions or state of the medium process deviate.

- ➔ Install the regulator free of stress and with the least amount of vibrations as possible. Read information under 'Mounting position' and 'Temperature sensor' in this chapter.
- ➔ Install the regulator allowing sufficient space to remove the control thermostat and valve or to perform service work on them.

#### Mounting position

To ensure that the regulator functions properly, proceed as follows:

- ➔ The regulator can be mounted in any position when the medium temperature is up to 80 °C/175 °F.
- ➔ At medium temperatures above 80 °C/175 °F and with steam, install it with the control thermostat suspended downward in horizontal pipelines (see Fig. 5-1).
- ➔ Make sure the direction of flow matches the direction indicated by the arrow on the body.
- ➔ Contact SAMSON if the mounting position is not as specified above.

---

#### **NOTICE**

##### **Damage due to freezing.**

*Protect the regulator from icing up when controlling media that can freeze. Unless the regulator is installed in locations where no frost occurs, remove the regulator from the pipeline when the plant is shut down.*

---

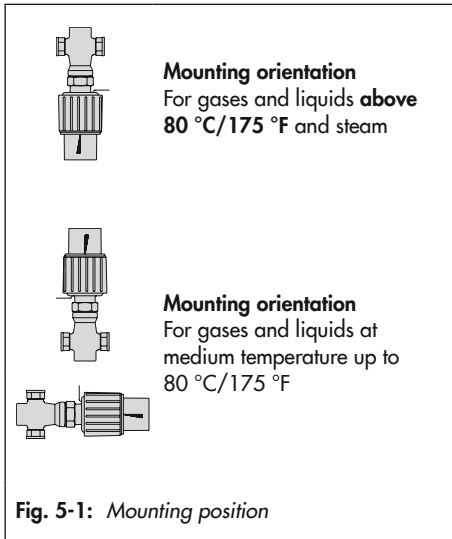

### Temperature sensor

→ See Fig. 5-2

#### **NOTICE**

#### **Galvanic corrosion due to incorrectly selected materials of the mounting parts.**

*On installing the sensor or thermowell, only combine the same kind of materials (e.g. stainless steel with stainless steel or copper together with other copper materials).*

The temperature sensor (19), even together with a thermowell (20), can be installed in any position as required. However, make sure its entire length is immersed in the process medium to be controlled. It must be installed in a location where overheating or considerable idling times cannot occur.

#### **Note**

*If the sensor is to be used with a thermowell, only use original SAMSON thermowells.*

Weld a welding socket with G ½ or G ¾ female thread (to match the screw gland) at the place of installation.

→ Seal the screw gland of the sensor.

#### **Installation with thermowell**

When a thermowell is used, a welding socket with G 1 female thread must be used.

1. Seal the thermowell into the welding socket.
2. Insert the sensor and tighten it with the clamping screw.

#### **Note**

*For temperature regulators with safety temperature limiter (TR/STL), install the sensor of the limiter near the control thermostat sensor.*

#### **Dynamic behavior of Type 2430 Control Thermostat**

The dynamics of the regulator are mainly determined by the response of the sensor with its characteristic time constant. Table 5-1 shows the dynamic behavior of the Type 2430 Control Thermostat measured in water.

#### **Capillary tube**

Carefully run the capillary tube without bending or twisting it. Avoid locations with considerable ambient temperature fluctuations along the entire length of the tube.

**i Note**

Do not damage or shorten the capillary tube. Roll up any capillary tube that is not used. The smallest permissible bending radius is 50 mm.

**Support and suspension****i Note**

The plant engineering company is responsible for selecting and implementing a suitable support or suspension of the installed regulator and the pipeline.

Depending on the regulator version and mounting position, the regulator and pipeline must be supported or suspended.

**ⓘ NOTICE**

Do not attach supports directly to the regulator.

**5.2 Preparation for installation**

Before installation, make sure the following conditions are met:

- The valve and control thermostat are clean.
- The valve, control thermostat and thermometer (if used) are not damaged.
- Install a strainer upstream of the valve.
- The valve and control thermostat data on the nameplates (type designation, valve

size, material, pressure rating and temperature range) match the plant conditions (size and pressure rating of the pipeline, medium temperature etc.). See the 'Markings on the device' chapter for nameplate details.

- The requested or required additional fittings have been installed or prepared as necessary before installing the valve and control thermostat (see the 'Design and principle of operation' chapter).

Proceed as follows:

- ➔ Lay out the necessary material and tools to have them ready during installation work.
- ➔ Flush the pipeline **before** installing the regulator.  
The plant operator is responsible for cleaning the pipelines in the plant.
- ➔ For steam applications, dry the pipelines. Moisture will damage the inside of the regulator.
- ➔ Check any mounted thermometers to make sure they function properly.

**i Note**

The plant operator is responsible for cleaning the pipelines in the plant.

## Installation

**Table 5-1:** Dynamic behavior of Type 2430 Control Thermostat (adsorption principle)

Type 2430	Sensor Ø	Time constant [s]	
		Without thermowell	With thermowell
Adsorption principle	9.5 mm/0.37 inch	15	40
	16 mm	30	80
	Air sensor	8	- <sup>1)</sup>

<sup>1)</sup> Thermowell not possible

**Table 5-2:** Inlet and outlet lengths

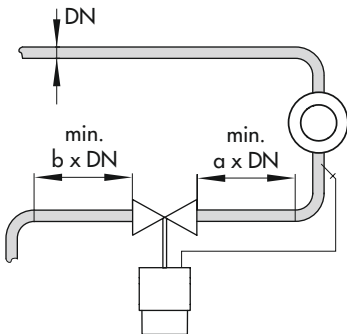
 <p style="text-align: right;">a Inlet length b Outlet length</p>			
State of process medium	Valve conditions	Inlet length a	Outlet length b
Gas	$Ma \leq 0.3$	2	4
Vapors <sup>1)</sup>	$Ma \leq 0.3$	2	4
Liquid	Free of cavitation/ $w < 3 \text{ m/s}$	2	4
	Cavitation producing noise/ $w \leq 3 \text{ m/s}$	2	4

<sup>1)</sup> No saturated steam



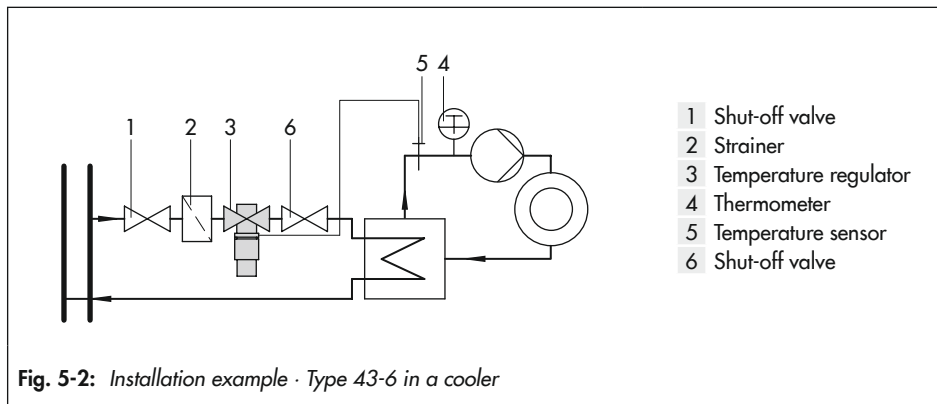

Fig. 5-2: Installation example · Type 43-6 in a cooler

### 5.3 Mounting

The components (valve, control thermostat and, if applicable, thermowell) of the regulator are delivered separately. The activities listed below are necessary for installation and before start-up of the regulator.

#### NOTICE

**Risk of regulator damage due to excessively high or low tightening torques.**

Observe the specified torques when tightening regulator components. Excessive tightening torques lead to parts wearing out more quickly. Parts that are too loose may cause leakage.

→ Observe the specified tightening torques (see 'Tightening torques' in the Appendix).

#### NOTICE

**Risk of regulator damage due to the use of unsuitable tools.**

→ Only use tools approved by SAMSON (see 'Tools' in the Appendix).

#### NOTICE

**Risk of regulator damage due to the use of unsuitable lubricants.**

→ Only use lubricants approved by SAMSON (see 'Lubricants' in the Appendix).

### 5.3.1 Installing the regulator

1. Close the shut-off valves upstream and downstream of the regulator while the regulator is being installed.
2. Remove the protective caps from the valve ports of valve with flanges before installation.
3. Observe the flow direction through the valve. The arrow on the valve indicates the direction of flow.
4. Make sure that the correct gaskets are used.
5. Bolt the pipe to the valve free of stress.
6. Slowly open the shut-off valves in the pipeline after the regulator has been installed.

### 5.3.2 Cleaning the pipeline

We recommend additionally flushing the pipeline without the installed regulator before start-up. In this case, install a suitable length of pipe into the pipeline in place of the regulator.

- Observe the mesh size of the upstream strainer for the maximum particle size. Use strainers to suit the process medium.
- Check the strainer for dirt each time the pipeline is flushed and clean it, if necessary.

### 5.4 Testing the regulator

---

#### **⚠ DANGER**

##### ***Risk of bursting due to incorrect opening of pressurized equipment or components.***

*Regulators and pipelines are pressure equipment that may burst when handled incorrectly. Flying projectile fragments or the release of process medium under pressure can cause serious injury or even death.*

*Before working on the regulator:*

- *Depressurize all plant sections concerned and the regulator.*
  - *Drain the process medium from all the plant sections concerned as well as the valve.*
- 

#### **⚠ DANGER**

##### ***Risk of personal injury due to process medium escaping.***

- *Do not start up the regulator until all parts have been mounted.*
- 

#### **⚠ WARNING**

##### ***Risk of hearing loss or deafness due to loud noise.***

*Noise emission (e.g. cavitation or flashing) may occur during operation caused by the process medium and the operating conditions.*

- *Wear hearing protection when working near the valve. Follow the instructions given by the plant operator.*
-

**⚠ WARNING**

**Risk of burn injuries due to hot or very cold components and pipelines.**

*Depending on the process medium, the regulator and pipelines may get very hot or cold and cause burn injuries.*

➔ *Wear protective clothing and safety gloves.*

SAMSON regulators are delivered ready for use. To test the regulator functioning before start-up or putting back the regulator into operation, perform the following tests:

### 5.4.1 Leak test

The plant operator is responsible for performing the leak test and selecting the test method. The leak test must comply with the requirements of the national and international standards that apply at the site of installation.

**💡 Tip**

*SAMSON's After-sales Service can support you to plan and perform a leak test for your plant.*

1. Slowly open the shut-off valve installed upstream of the regulator.
2. Apply the required test pressure.
3. Check the regulator for leakage to the atmosphere.
4. Check the screw gland of the sensor or thermowell for leakage.
5. Depressurize the pipeline section and regulator.
6. Rework any parts that leak and repeat the leak test.

### 5.4.2 Pressure test

**i Note**

*The plant operator is responsible for performing the pressure test. SAMSON's After-sales Service can support you to plan and perform a pressure test for your plant.*

**⚠ NOTICE**

*Risk of regulator damage due to a sudden pressure increase and resulting high flow velocities.*

➔ *Slowly open the shut-off valves.*

During the pressure test, make sure the following conditions are met:

- Do not allow the pressure to exceed the 1.5 times the pressure rating of the valve body.
- The valve must remain open.  
Therefore, adjust the lowest temperature set point to ensure that the regulator does not close.
- Make sure that the pressure rises simultaneously upstream and downstream of the regulator to avoid damaging the balancing bellows/plug.

## 5.5 Insulation

To insulate cold systems, we recommend first filling the plant and carefully rinsing it. The regulator must not yet be insulated at this stage.

---

### ! NOTICE

#### ***Risk of regulator damage due to incorrect insulation.***

- *Only insulate the regulator up to the control thermostat for medium temperatures below 0 °C/32 °F or above 80 °C/175 °F.*

- 
1. Start up the plant and adjust the set point (see the 'Start-up' chapter).
  2. Shut down the plant again and let it heat up until the condensation water has dried off.
  3. Insulate the regulator and pipes conveying the process medium using insulation material with a water vapor barrier. If an external control line is to be routed through the insulation, special care must be taken with the sealing since slight changes in shape may occur. The insulation thickness depends on the medium temperature and the ambient conditions. 50 mm is a typical thickness.

## 6 Start-up

The work described in this chapter is only to be performed by personnel appropriately qualified to carry out such tasks.

### **⚠ DANGER**

**Risk of personal injury due to process medium escaping.**

→ Do not start up the regulator until all parts have been mounted.

### **⚠ WARNING**

**Risk of burn injuries due to hot or cold components and pipeline.**

Regulator components and the pipeline may become very hot or cold. Risk of burn injuries.

→ Allow components and pipelines to cool down or warm up to the ambient temperature.

→ Wear protective clothing and safety gloves.

### **⚠ WARNING**

**Risk of hearing loss or deafness due to loud noise.**

Noise emission (e.g. cavitation or flashing) may occur during operation caused by the process medium and the operating conditions.

→ Wear hearing protection when working near the valve. Follow the instructions given by the plant operator.

### **ⓘ NOTICE**

**Risk of overheating due to excessive ambient temperatures or insufficient heat dissipation when components are insulated.**

– Do not include the regulator in the insulation of the pipeline.

### **ⓘ NOTICE**

**Risk of impaired functioning of the regulator and leakage at the joint due to installation under tension.**

– Bolt the regulator to the pipeline free of stress.

– If necessary, support the pipelines near to the connections.

– Do not attach supports directly to the valve or control thermostat.

Before start-up or putting the device back into service, make sure the following conditions are met:

- The regulator is properly installed into the pipeline (see the 'Installation' chapter).
- The leak and function tests have been completed successfully (see the 'Testing the regulator' chapter).
- The prevailing conditions in the plant section concerned meet the regulator sizing requirements (see information under 'Intended use' in the 'Safety instructions and measures' chapter).

### 6.1 Start-up and putting the regulator back into operation

1. Depending on the field of application, allow the regulator to cool down or warm up to reach ambient temperature before start up.
2. Slowly open the shut-off valves in the pipeline. Slowly opening these valves prevents a sudden surge in pressure and high flow velocities which can damage the valve.
3. Check the regulator to ensure it functions properly.

#### 6.1.1 Starting up the plant when gases and liquids are controlled

1. Open the shut-off valves slowly preferably starting from the upstream pressure side. Afterwards, open all the valves on the consumer side (downstream of the regulator).
2. Fill the plant **slowly** with the process medium. Avoid pressure surges.
3. Make sure that the pressure rises simultaneously upstream and downstream of the regulator to avoid damaging the balancing bellows/plug.
4. To start up the regulator, open shut-off valves **slowly**.
5. Check the adjusted temperature set point at the thermometer installed near the temperature sensor.

#### 6.1.2 Starting up the plant when vapors are controlled

1. Completely drain and dry steam lines to prevent water hammering.
2. Slowly allow the steam to enter the plant to ensure that the pipes and valves warm up evenly and to avoid excessive flow velocities.
3. Before the full capacity is reached, drain off the start-up condensate.
4. Make sure that the air contained in the plant escapes as quickly as possible.
5. Open the shut-off valves slowly preferably starting from the upstream pressure side.
6. Avoid pressure surges.
7. Check the adjusted temperature set point at the thermometer installed near the temperature sensor.

## 7 Operation

Immediately after completing start-up or placing the regulator back into service (see the 'Start-up' chapter), the regulator is ready for use.

### **⚠ WARNING**

**Risk of burn injuries due to hot or cold components and pipeline.**

*Regulator components and the pipeline may become very hot or cold. Risk of burn injuries.*

- *Allow components and pipelines to cool down or warm up to the ambient temperature.*
- *Wear protective clothing and safety gloves.*

### **⚠ WARNING**

**Risk of hearing loss or deafness due to loud noise.**

*Noise emission (e.g. cavitation or flashing) may occur during operation caused by the process medium and the operating conditions.*

- *Wear hearing protection when working near the valve. Follow the instructions given by the plant operator.*

## 7.1 Adjusting the temperature set point

Adjust the required set point by turning the set point adjuster (43) by hand. The adjustment diagrams (see Fig. 7-3) can be used as a guide to find the first approximate value.

### Set point adjuster

- Turn the set point adjuster clockwise (↻) to increase the temperature set point.
- Turn the set point adjuster counterclockwise (↺) to reduce the temperature set point.

The thermometer (4) installed on the downstream side on site allows the adjusted set point to be monitored.

### **i Note**

*Higher set point temperatures can be adjusted in increments as required. However, to lower the set point temperature, proceed in steps of 10 to 20 °C/50 to 68 °F. When doing so, wait for the process medium to cool down before continuing. Watch the thermometer.*

**Type 43-6 (DIN)**

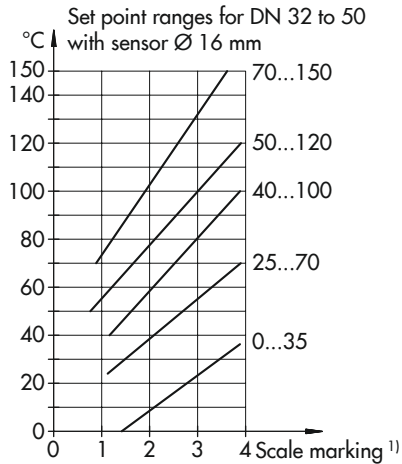
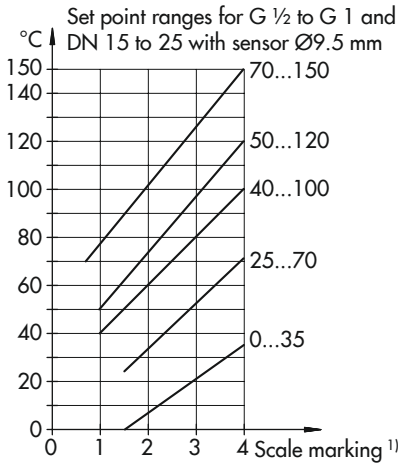

**Type 43-6 (ANSI)**

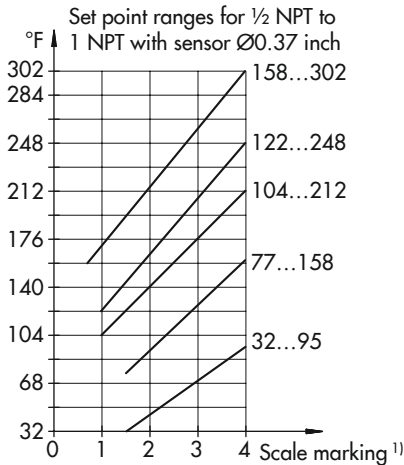

**Table 7-3: Set point ranges**

Set point range	Set point change per turn	Sensor Ø
0 to 35 °C 32 to 95 °F	2.5 °C 4.5 °F	9.5 mm 0.37 inch
	2 °C	16 mm
25 to 70 °C 77 to 158 °F	3 °C 5.4 °F	9.5 mm 0.37 inch
	2 °C	16 mm
40 to 100 °C 104 to 212 °F	4 °C 7.2 °F	9.5 mm 0.37 inch
	3 °C	16 mm
50 to 120 °C 122 to 248 °F	4 °C 7.2 °F	9.5 mm 0.37 inch
	4.5 °C	16 mm
70 to 150 °C 158 to 302 °F	4.5 °C 8.1 °F	9.5 mm 0.37 inch
	5 °C	16 mm

**Fig. 7-3: Adjustment diagrams**

<sup>1)</sup> On the thermostat head



## 8 Malfunctions

### 8.1 Troubleshooting

Malfunction	Possible reasons	Recommended action
Temperature at the sensor exceeds the set point.	Seat and plug are worn or leak.	<ul style="list-style-type: none"> <li>→ Clean the seat and plug.</li> <li>→ Replace the damaged seat and plug.</li> <li>→ Contact SAMSON's After-sales Service.</li> </ul>
	Foreign particles blocking the plug	<ul style="list-style-type: none"> <li>→ Remove foreign particles.</li> <li>→ Replace damaged parts.</li> <li>→ Contact SAMSON's After-sales Service.</li> </ul>
	A safety device (e.g. STL or STM) has been triggered.	→ Check plant. Unlock safety device (where necessary).
	Sensor installed in the wrong location.	→ Change the mounting position.
	Sensor installed incorrectly.	<ul style="list-style-type: none"> <li>→ Immerse the temperature sensor with its entire immersion depth in the process medium.</li> <li>→ Avoid an installation site where idle times or heat buildup can occur.</li> </ul>
	Regulator or $K_{VS}/C_V$ coefficient too large	<ul style="list-style-type: none"> <li>→ Check the sizing.</li> <li>→ Change <math>K_{VS}/C_V</math> coefficient, if necessary or install a different sized regulator.</li> <li>→ Contact SAMSON's After-sales Service.</li> </ul>
Temperature at the sensor fluctuates.	Regulator or $K_{VS}/C_V$ coefficient too large	<ul style="list-style-type: none"> <li>→ Check the sizing.</li> <li>→ Change <math>K_{VS}/C_V</math> coefficient, if necessary or install a different sized regulator.</li> <li>→ Contact SAMSON's After-sales Service.</li> </ul>
	Sensor installed in the wrong location.	→ Change the mounting position.
	Sensor installed incorrectly.	<ul style="list-style-type: none"> <li>→ Immerse the temperature sensor with its entire immersion depth in the process medium.</li> <li>→ Avoid an installation site where idle times or heat buildup can occur.</li> </ul>
Slow control response	Time constant is too large for the control loop.	<ul style="list-style-type: none"> <li>→ Fill the thermowell with thermal paste or remove the thermowell.</li> <li>→ Use a sensor with smaller time constant (e.g. vapor pressure thermostat).</li> </ul>
	Sensor installed incorrectly.	<ul style="list-style-type: none"> <li>→ Immerse the temperature sensor with its entire immersion depth in the process medium.</li> <li>→ Avoid an installation site where idle times or heat buildup can occur.</li> </ul>

## Malfunctions

Malfunction	Possible reasons	Recommended action
Temperature at the sensor does not reach the set point.	Control thermostat defective	→ Replace the control thermostat.
	Valve installed against the flow.	→ Install the valve so that the direction of flow matches the direction indicated by the arrow on the body.
	Strainer blocked.	→ Clean the strainer.
	Regulator or $K_{VS}/C_V$ coefficient too small	→ Check the sizing. → Change $K_{VS}/C_V$ coefficient, if necessary or install a different sized regulator. → Contact SAMSON's After-sales Service.
	Insufficient heating energy available	→ Draw up an energy balance.
	Foreign particles blocking the plug	→ Remove foreign particles. → Replace damaged parts. → Contact SAMSON's After-sales Service.
	Sensor installed in the wrong location.	→ Change the mounting position.
	Sensor installed incorrectly.	→ Immerse the temperature sensor with its entire immersion depth in the process medium. → Avoid an installation site where idle times or heat buildup can occur.
Jerky control response	Increased friction, e.g. due to foreign particles between seat and plug.	→ Remove foreign particles. → Replace damaged parts. → Contact SAMSON's After-sales Service.
Loud flow-induced noise	High flow velocity, cavitation.	→ Check the sizing. → Install larger regulator, if necessary.
Leak between control thermostat and valve	Valve seal defective	→ Contact SAMSON's After-sales Service.

### **i** Note

Contact SAMSON's After-sales Service for malfunctions not listed in the table.

The malfunctions listed in Chapter 8.1 are caused by mechanical faults and incorrect regulator sizing. In the simplest case, the functioning can be restored following the recommended action. Special tools may be required to rectify the fault.

Exceptional operating and installation conditions may lead to changed situations that may affect the control response and lead to malfunctions. For troubleshooting, the conditions, such as installation, process medium, temperature and pressure conditions, must be taken into account.

**Tip**

*SAMSON's After-sales Service can support you in drawing up an inspection and test plan for your plant.*

---

## 8.2 Emergency action

Plant operators are responsible for emergency action to be taken in the plant.

We recommend removing the regulator from the pipeline before repairing it.

In the event of a regulator malfunction:

1. Close the shut-off valves upstream and downstream of the regulator to stop the process medium from flowing through the regulator.
2. Perform troubleshooting (see Chapter 8.1).
3. Rectify those malfunctions that can be remedied based on the instructions provided here. Contact SAMSON's After-sales Service in all other cases.

### **Putting the regulator back into operation after a malfunction**

See the 'Start-up' chapter.



## 9 Servicing

The regulator does not require much maintenance. Nevertheless, it is subject to natural wear, particularly at the seat, plug and control thermostat. Depending on the operating conditions, check the regulator at regular intervals to avoid possible malfunctions. Plant operators are responsible for drawing up an inspection and test plan. Details on faults and how to remedy them can be found in the 'Malfunctions' chapter.

The work described in this chapter is to be performed only by personnel appropriately qualified to carry out such tasks.

SAMSON recommends removing the regulator from the pipeline before performing any maintenance or service work.

---

### **⚠ WARNING**

**Risk of burn injuries due to hot or cold components and pipeline.**

*Regulator components and the pipeline may become very hot or cold. Risk of burn injuries.*

- ➔ *Allow components and pipelines to cool down or warm up to the ambient temperature.*
  - ➔ *Wear protective clothing and safety gloves.*
- 

---

### **⚠ WARNING**

**Risk of personal injury due to residual process medium in the regulator.**

*While working on the regulator, residual process medium can escape and, depending on its properties, may lead to personal injury, e.g. (chemical) burns.*

- ➔ *Wear protective clothing, safety gloves and eye protection.*
- 

---

### **⚠ NOTICE**

**Risk of regulator damage due to over- or under-torquing.**

*Observe the specified torques when tightening regulator components. Excessive tightening torques lead to parts wearing out more quickly. Parts that are too loose may cause leakage.*

- ➔ *Observe the specified tightening torques (see the 'Tightening torques' chapter in the Appendix).*
- 

---

### **⚠ NOTICE**

**Risk of regulator damage due to the use of unsuitable tools.**

- ➔ *Only use tools approved by SAMSON (see the 'Tools' chapter in the Appendix).*
-

### NOTICE

**Risk of regulator damage due to the use of unsuitable lubricants.**

→ Only use lubricants approved by SAMSON (see the 'Lubricants' chapter in the Appendix).

### Note

**The regulator was checked by SAMSON before it left the factory.**

- Certain test results certified by SAMSON lose their validity when the regulator is opened. Such testing includes seat leakage and leak tests.
- The product warranty becomes void if service or repair work not described in these instructions is performed without prior agreement by SAMSON's After-sales Service.
- Only use original spare parts by SAMSON, which comply with the original specifications.

### Tip

SAMSON's After-sales Service can support you in drawing up an inspection and test plan for your plant.

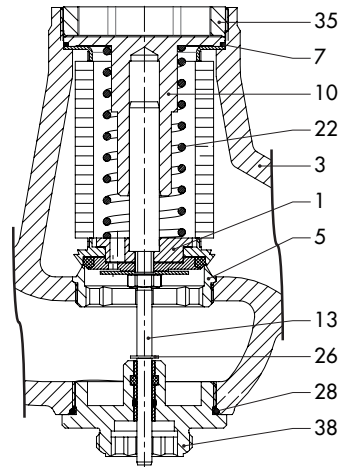

- 1 Plug assembly
- 3 Body
- 5 Seat
- 7 Seal
- 10 Guide bushing
- 13 Pin
- 22 Valve spring
- 26 Retaining washer
- 28 Seal
- 35 Stopper
- 38 Guide nipple

**Fig. 9-1:** Functional diagram of regulator, DN 32 to 50

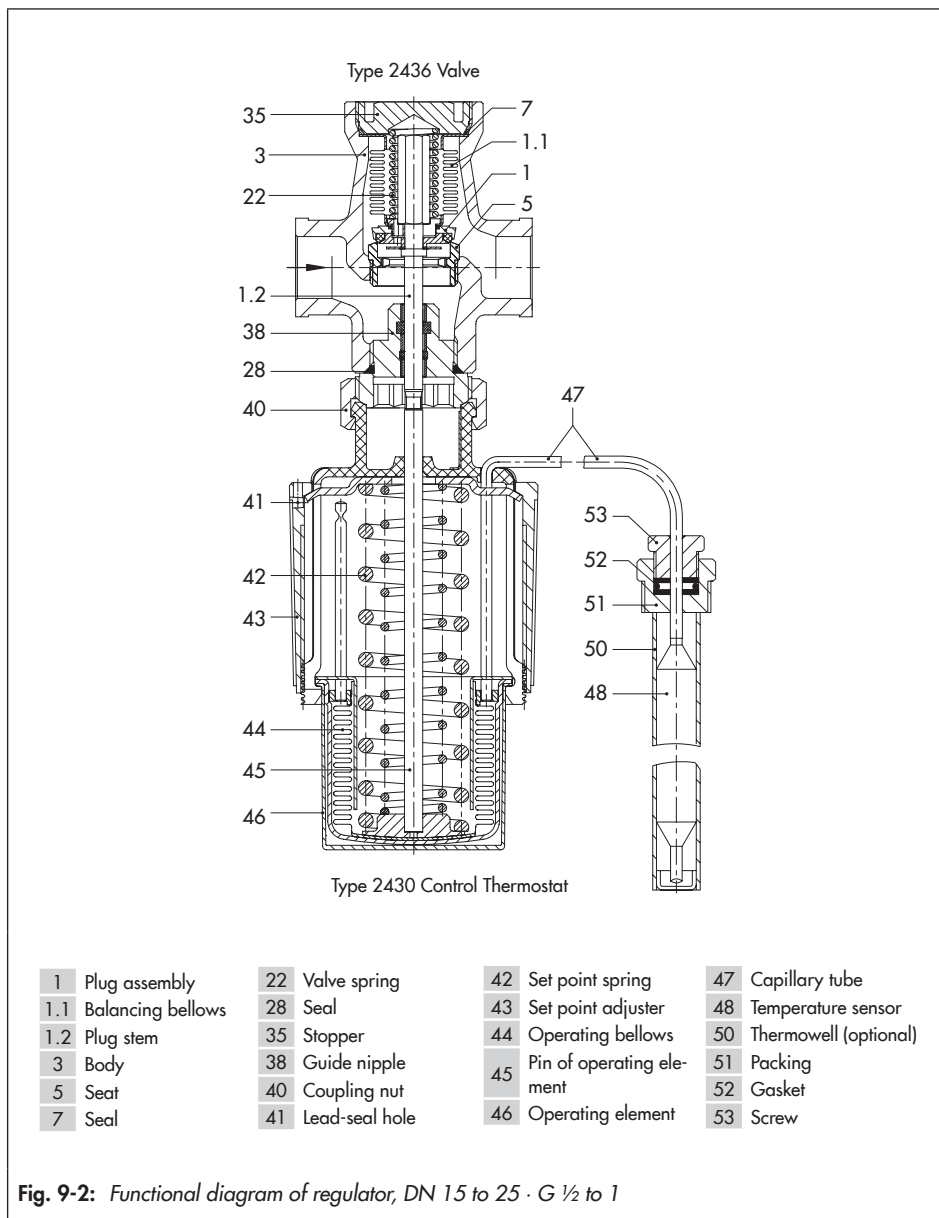

Fig. 9-2: Functional diagram of regulator, DN 15 to 25 · G ½ to 1

### 9.1 Service work preparations

1. Lay out the necessary material and tools to have them ready for the service work.
2. Put the regulator out of operation (see the 'Decommissioning' chapter).



#### Tip

SAMSON recommends removing the regulator from the pipeline before performing any service work (see the 'Removing the regulator from the pipeline' chapter).

The following service work can be performed after preparation is completed:

- Clean and exchange the seat and plug (see Chapter 9.4)

### 9.2 Installing the regulator after service work

- Put the regulator back into operation (see the 'Start-up' chapter). Make sure the requirements and conditions for start-up or putting the valve back into operation are met.

### 9.3 Service work

- Before performing any service work, preparations must be made to the regulator (see Chapter 9.1).
- After all service work is completed, check the regulator before putting it back into operation (see section 'Testing the regulator' in the 'Installation' chapter).

### 9.4 Cleaning and exchanging the seat and plug

#### NOTICE

**Risk of regulator damage due to over- or under-torquing.**

Observe the specified torques when tightening regulator components. Excessive tightening torques lead to parts wearing out more quickly. Parts that are too loose may cause leakage.

Observe the specified tightening torques.

#### NOTICE

**Risk of damage to the facing of the seat and plug due to incorrect service or repair.**

Always replace both the seat and plug.

#### Note

SAMSON's After-sales Service can support you concerning lubricant, tightening torques and tools approved by SAMSON.

- See Fig. 9-1 and Fig. 9-2

#### Valve disassembly (DN 15 to 25)

1. Unscrew the coupling nut (40) from the valve and remove the control thermostat.
2. Remove the valve from the pipeline.
3. Unscrew the stopper (35) with socket wrench (width across flats A/F 19)<sup>1)</sup>.
4. Remove the seal (7).



5. Pull out plug assembly (1).
6. Thoroughly clean the seat (5) and plug (1). If the plug, balancing bellows or the surface of the plug stem (1.2) is damaged, replace the entire unit with a new one.
7. When the surface of the plug stem (1.2) or plug (1) is damaged, unscrew the guide nipple (38) with an Allen key (width across flats A/F 19)<sup>1)</sup>. Remove the seal (28). Replace plug (1), guide nipple (38) and seal (28) with new parts.
8. Unscrew the seat (5) using a seat wrench<sup>1)</sup> if the seat facing is damaged. Replace with a new one.

#### Valve disassembly (DN 32 to 50)

1. Unscrew the coupling nut (40) from the valve and remove the control thermostat.
2. Remove the valve from the pipeline.
3. Unscrew the stopper (35) with Allen key (width across flats A/F 39)<sup>1)</sup>.
4. Remove the seal (7).
5. Pull out plug assembly (1) together with guide bushing (10).
6. Thoroughly clean the seat (5) and plug (1). If the plug or balancing bellows is damaged, replace the entire unit with a new one.
7. Pull out the pin (13). When the surface of the pin (13) is damaged, unscrew the guide nipple (38) with an Allen key (width across flats A/F 19)<sup>1)</sup>. Remove the seal (28). Replace pin (13), guide nipple (38) and seal (28) with new parts.

8. Unscrew the seat (5) using a seat wrench<sup>1)</sup> if the seat facing is damaged. Replace with a new one.

#### Valve assembly (DN 15 to 25)

1. Screw in the seat (5) using a seat wrench<sup>1)</sup>. Observe the specified tightening torques (see the 'Tightening torques' chapter in the Appendix).
2. Insert new seal (28) and screw in the guide nipple (38) with an Allen key (width across flats A/F 19)<sup>1)</sup>. Observe the specified tightening torques (see the 'Tightening torques' chapter in the Appendix).
3. Insert plug assembly (1) together with plug stem (1.2) into the guide nipple (38).
4. Insert a new seal (7) into the body.
5. Screw in the stopper (35) with socket wrench (width across flats A/F 19)<sup>1)</sup>. Observe the specified tightening torques (see the 'Tightening torques' chapter in the Appendix).
6. Install the valve into the pipeline.
7. Fasten the control thermostat on the valve using the coupling nut (40).

#### Valve assembly (DN 32 to 50)

1. Screw in the seat (5) using a seat wrench<sup>1)</sup>. Observe the specified tighten-

<sup>1)</sup>Contact SAMSON concerning the special tool.

## Servicing

ing torques (see the 'Tightening torques' chapter in the Appendix).

2. Insert new seal (28) and screw in the guide nipple (38) with an Allen key (width across flats A/F 19)<sup>1)</sup>. Observe the specified tightening torques (see the 'Tightening torques' chapter in the Appendix).
3. Insert pin (13) into the guide nipple (38).
4. Insert plug assembly (1) together with guide bushing (10) into the body.
5. Insert a new seal (7) into the body.
6. Screw in the stopper (35) with socket wrench (width across flats A/F 19)<sup>1)</sup>. Observe the specified tightening torques (see the 'Tightening torques' chapter in the Appendix).
7. Install the valve into the pipeline.
8. Fasten the control thermostat on the valve using the coupling nut (40).

## 9.5 Ordering spare parts and operating supplies

Contact your nearest SAMSON subsidiary or SAMSON's After-sales Service for information on spare parts, lubricants and tools.

### Spare parts

See the Appendix for details on spare parts.

### Lubricants

Contact SAMSON's After-sales Service for more information on lubricants.

### Tools

Contact SAMSON's After-sales Service for more information on tools.

<sup>1)</sup> Contact SAMSON concerning the special tool.

## 10 Decommissioning

The work described in this chapter is only to be performed by personnel appropriately qualified to carry out such tasks.

### **⚠ DANGER**

**Risk of bursting due to incorrect opening of pressurized equipment or components.**

Regulators and pipelines are pressure equipment that may burst when handled incorrectly. Flying projectile fragments or the release of process medium under pressure can cause serious injury or even death.

Before working on the regulator:

- Depressurize all plant sections concerned and the regulator.
- Shut off an external control line.
- Drain the process medium from all the plant sections affected as well as the regulator.

### **⚠ WARNING**

**Risk of burn injuries due to hot or cold components and pipeline.**

Regulator components and the pipeline may become very hot or cold. Risk of burn injuries.

- Allow components and pipelines to cool down or warm up to the ambient temperature.
- Wear protective clothing and safety gloves.

### **⚠ WARNING**

**Risk of personal injury due to pressurized components and process medium being discharged.**

- Do not loosen the external control line while the valve is pressurized.

### **⚠ WARNING**

**Risk of hearing loss or deafness due to loud noise.**

Noise emission (e.g. cavitation or flashing) may occur during operation caused by the process medium and the operating conditions.

- Wear hearing protection when working near the valve. Follow the instructions given by the plant operator.

### **⚠ WARNING**

**Risk of personal injury due to residual process medium in the regulator.**

While working on the regulator, residual process medium can escape and, depending on its properties, may lead to personal injury, e.g. (chemical) burns.

- Wear protective clothing, safety gloves and eye protection.

## Decommissioning

To decommission the regulator for service work or disassembly, proceed as follows:

1. Close the shut-off valve (1 and 6) on the downstream and upstream side of the regulator.
2. Close any shut-off valve installed on the downstream and upstream side of the sensor if a thermowell is not used.
3. Completely drain the pipelines and regulator.
4. Depressurize the plant.
5. If necessary, allow the pipeline and regulator components to cool down or warm up to the ambient temperature.

## 11 Removal

The work described in this chapter is only to be performed by personnel appropriately qualified to carry out such tasks.

### **⚠ WARNING**

#### ***Risk of burn injuries due to hot or cold components and pipeline.***

*Regulator components and the pipeline may become very hot or cold. Risk of burn injuries.*

- *Allow components and pipelines to cool down or warm up to the ambient temperature.*
- *Wear protective clothing and safety gloves.*

### **⚠ WARNING**

#### ***Risk of personal injury due to residual process medium in the regulator.***

*While working on the regulator, residual process medium can escape and, depending on its properties, may lead to personal injury, e.g. (chemical) burns.*

- *Wear protective clothing, safety gloves and eye protection.*

Before removing the valve, make sure the following conditions are met:

- The regulator is put out of operation (see the 'Decommissioning' chapter).

### 11.1 Removing the control thermostat

1. Pull the sensor out of the thermowell. In cases where a thermowell is not used, unscrew the screw gland and pull out the sensor.
2. Unscrew the control thermostat from the valve (width across flats 36).

### 11.2 Removing the valve from the pipeline

1. Support the regulator to hold it in place when separated from the pipeline (see the 'Shipment and on-site transport' chapter).
2. Unbolt the pipe/flange joint.
3. Remove the regulator from the pipeline (see the 'Shipment and on-site transport' chapter).



## 12 Repairs

If the regulator does not function properly according to how it was originally sized or does not function at all, it is defective and must be repaired or exchanged.

### ! NOTICE

**Risk of regulator damage due to incorrect service or repair work.**

- ➔ Do not perform any repair work on your own.
- ➔ Contact SAMSON's After-sales Service for repair work.

### 12.1 Returning devices to SAMSON

Defective devices can be returned to SAMSON for repair.

Proceed as follows to return devices:

1. Exceptions apply concerning some special device models
  - ▶ [www.samsongroup.com](http://www.samsongroup.com) > Service > After-sales Service.
2. Send an e-mail ▶ [retouren@samsongroup.com](mailto:retouren@samsongroup.com) to register the return shipment including the following information:

- Type
- Article no.
- Material number
- Original order
- Completed Declaration on Contamination, which can be downloaded from our website at
  - ▶ [www.samsongroup.com](http://www.samsongroup.com) > Service > After-sales Service.

**After checking your registration, we will send you a return merchandise authorization (RMA).**

3. Attach the RMA (together with the Declaration on Decontamination) to the outside of your shipment so that the documents are clearly visible.
4. Send the shipment to the address given on the RMA.

### i Note

*Further information on returned devices and how they are handled can be found at*

- ▶ [www.samsongroup.com](http://www.samsongroup.com) > Service > After-sales Service.





## 13 Disposal



SAMSON is a producer registered at the following European institution ► <https://www.samsongroup.com/en/about-samson/environment-social-governance/material-compliance/waste-electrical-and-electronic-equipment-veee-and-its-safe-disposal/>.  
WEEE reg. no.: DE 62194439

---

### Tip

*On request, SAMSON can appoint a service provider to dismantle and recycle the product as part of a distributor take-back scheme.*

---

Information on substances listed as substances of very high concern (SVHC) on the candidate list of the REACH regulation can be found in the document "Additional Information on Your Inquiry/Order", which is added to the order documents, if applicable. This document includes the assigned SCIP number, which can be entered into the database on the European Chemicals Agency (ECHA) website (► <https://www.echa.europa.eu/scip-database>) to find out more information on the SVHC.

- ➔ Observe local, national and international refuse regulations.
- ➔ Do not dispose of components, lubricants and hazardous substances together with your other household waste.

---

### Note

*SAMSON can provide you with a recycling passport according to PAS 1049 on request. Simply e-mail us at [aftersaleservice@samsongroup.com](mailto:aftersaleservice@samsongroup.com) giving details of your company address.*

---



## 14 Certificates

The EU declarations of conformity are included on the next pages:

- EU declaration of conformity in compliance with Pressure Equipment Directive 2014/68/EU on page 14-2.

SMART IN FLOW CONTROL.



**EU-KONFORMITÄTSERKLÄRUNG  
EU DECLARATION OF CONFORMITY**

**Modul H/Module H, Nr./No. / N° CE-0062-PED-H-SAM 001-16-DEU-rev-A**

SAMSON erklärt in alleiniger Verantwortung für folgende Produkte:/For the following products, SAMSON hereby declares under its sole responsibility:

**Ventile für Temperaturregler/Valves for temperature regulators**

Typ/Type 2431, 2432, 2435, 2436, 2437 (Erz.-Nr./Model No. 2710)

die Konformität mit nachfolgender Anforderung/the conformity with the following requirement.

Richtlinie des Europäischen Parlaments und des Rates zur Harmonisierung der Rechtsvorschriften der Mitgliedstaaten über die Bereitstellung von Druckgeräten auf dem Markt. 2014/68/EU vom 15.05.2014

Directive of the European Parliament and of the Council on the harmonization of the laws of the Member States relating to the making available on the market of pressure equipment. 2014/68/EU of 15 May 2014

Angewandtes Konformitätsbewertungsverfahren für Fluide nach Art. 4(1)(c.i) erster Gedankenstrich. Modul siehe Tabelle durch certified by Bureau Veritas S. A. (0062)  
Conformity assessment procedure applied for fluids according to Article 4(1)(c.i), first indent. See table for module

DN	15	20	25	32	40	50	65	80	100	125	150	200	250	300	400
NPS	½	¾	1	1¼	1½	2	-	3	4	-	6	8	10	12	16
PN 16 / PN 25	ohne <sup>(1)</sup>		A <sup>(2)(4)</sup>						H						
PN 40	ohne <sup>(1)</sup>								H						
Class 150	ohne <sup>(1)</sup>		A <sup>(2)(4)</sup>						H						
Class 300	ohne <sup>(1)</sup>								H						

(1) Das auf dem Stellgerät aufbrachte CE-Zeichen hat keine Gültigkeit im Sinne der Druckgeräterichtlinie.  
The CE marking affixed to the control device does not refer to the Pressure Equipment Directive.

(2) Das auf dem Stellgerät aufbrachte CE-Zeichen gilt ohne Bezeichnung der Notifizierten Stelle (Kennr. 0062).  
The CE marking affixed to the control device is valid, but does not refer to the notified body (ID No. is invalid).

(3) DN 15 auch in PN 16 lieferbar.  
DN 15 as well in PN deliverable.

(4) Die Identifikationsnummer 0062 von Bureau Veritas S.A. gilt nicht für Modul A.  
The identification number 0062 of Bureau Veritas S.A. is not valid for Modul A.

Geräte, denen laut Tabelle das Konformitätsbewertungsverfahren Modul H zugrunde liegt, beziehen sich auf die „Zulassungsbescheinigung eines Qualitätssicherungssystems“ ausgestellt durch die benannte Stelle.

Devices whose conformity has been assessed based on Module H refer to the certificate of approval for the quality management system issued by the notified body.

Dem Entwurf zu Grunde gelegt sind Verfahren aus:/The design is based on the procedures specified in the following standards:  
DIN EN 12516-2, DIN EN 12516-3 bzw./or ASME B16.24, ASME B16.34

Das Qualitätssicherungssystem des Herstellers wird von folgender benannter Stelle überwacht:  
The manufacturer's quality management system is monitored by the following notified body:

**Bureau Veritas S.A. Nr./No. 0062, Newtime, 52 Boulevard du Parc, Ile de la Jatte, 92200 Neuilly sur Seine, France  
Hersteller/Manufacturer: SAMSON AG, Weismüllerstraße 3, 60314 Frankfurt am Main, Germany**

Frankfurt am Main, 08. Februar 2017/08 February 2017

*Klaus Hörtschken*  
Klaus Hörtschken  
Zentralabteilungsleiter/Head of Central Department  
Entwicklung Ventile und Antriebe/R&D, Valves and Actuators

*Dr. Michael Heß*  
Dr. Michael Heß  
Zentralabteilungsleiter/Head of Central Department  
Product Management & Technical Sales

EU-Konformitätserklärung, Blatt 08, Modul-A, Modul-H, DE-EN, Rev.03, 2017-02-08.doc

SAMSON AKTIENGESELLSCHAFT  
Weismüllerstraße 3 60314 Frankfurt am Main

Telefon: 069 4009-0 · Telefax: 069 4009-1507  
E-Mail: samson@samson.de

Revision 03

SMART IN FLOW CONTROL.



**EU-KONFORMITÄTSERKLÄRUNG  
EU DECLARATION OF CONFORMITY**

**Modul H/Module H, Nr./No. / N° CE-0062-PED-H-SAM 001-16-DEU-rev-A**

SAMSON erklärt in alleiniger Verantwortung für folgende Produkte:/For the following products, SAMSON hereby declares under its sole responsibility.

**Ventile für Temperaturregler/Valves for temperature regulators**

Typ/Type 2111, 2121, 2431, 2432, 2435, 2436, 2437 (Erz.-Nr./Model No. 2710), 2433, 2118 (2713), 2119 (2803), 2111, 2121 (2811), 2114 (2814)

die Konformität mit nachfolgender Anforderung/the conformity with the following requirement.

Richtlinie des Europäischen Parlaments und des Rates zur Harmonisierung der Rechtsvorschriften der Mitgliedstaaten über die Bereitstellung von Druckgeräten auf dem Markt. 2014/68/EU vom 15.05.2014

Directive of the European Parliament and of the Council on the harmonization of the laws of the Member States regarding the making available on the market of pressure equipment. 2014/68/EU of 15 May 2014

Angewandtes Konformitätsbewertungsverfahren für Fluide nach Art. 4(1)(c.ii) und (c.i) zweiter Gedankenstrich. Modul siehe Tabelle durch certified by Bureau Veritas S. A. (0062)

Conformity assessment procedure applied for fluids according to Article 4(1)(c.ii) and (c.i), second indent See table for module

Nenndruck Pressure rating	DN NPS	15 ½	20 ¾	25 1	32 1¼	40 1½	50 2	65	80 3	100 4	125	150 6	200 8	250 10	
PN 16		ohne/without (1)						A (2)(3)		A (2)(3)		H			
PN 25		ohne/without (1)						A (2)(3)		A (2)(3)		H			
PN 40		ohne/without (1)				A (2)(3)		A (2)(3)		A (2)(3)		H			
Class 150		ohne/without (1)						A (2)(3)		A (2)(3)		H			
Class 300		ohne/without (1)						A (2)(3)		A (2)(3)		H			

- (1) Das auf dem Stellgerät aufgebrauchte CE-Zeichen hat keine Gültigkeit im Sinne der Druckgeräterichtlinie. The CE marking affixed to the control valve is not valid in the sense of the Pressure Equipment Directive.
- (2) Das auf dem Stellgerät aufgebrauchte CE-Zeichen gilt ohne Bezeichnung der benannten Stelle (Kenn-Nr. 0062). The CE marking affixed to the control valve is valid without specifying the notified body (ID number 0062).
- (3) Die Identifikationsnummer 0062 von Bureau Veritas S.A. gilt nicht für Modul A. The identification number 0062 of Bureau Veritas S.A. is not valid for Modul A.

Geräte, denen laut Tabelle das Konformitätsbewertungsverfahren Modul H zugrunde liegt, beziehen sich auf die „Zulassungsbescheinigung eines Qualitätssicherungssystems“ ausgestellt durch die Notifizierte Stelle. Devices whose conformity has been assessed based on Module H refer to the certificate of approval for the quality management system issued by the notified body.

Dem Entwurf zu Grunde gelegt sind Verfahren aus:/The design is based on the procedures specified in the following standards: DIN EN 12516-2, DIN EN 12516-3 bzw./or ASME B16.1, ASME B16.24, ASME B16.34, ASME B16.42

Das Qualitätssicherungssystem des Herstellers wird von folgender benannter Stelle überwacht The manufacturer's quality management system is monitored by the following notified body:

**Bureau Veritas S.A. Nr./No. 0062, Newtime, 52 Boulevard du Parc, Ile de la Jatte, 92200 Neuilly sur Seine, France  
Hersteller/Manufacturer: SAMSON AG, Weismüllerstraße 3, 60314 Frankfurt am Main, Germany**

Frankfurt am Main, 08. Februar 2017/08 February 2017

*Klaus Hörschken*  
Klaus Hörschken  
Zentralabteilungsleiter/Head of Central Department  
Entwicklung Ventile und Antriebe/R&D, Valves and Actuators

*Dr. Michael Heß*  
Dr. Michael Heß  
Zentralabteilungsleiter/Head of Central Department  
Product Management & Technical Sales

EU-Konformitätserklärung, Blatt 03\_Modul-A\_Modul-H\_DEU\_EN\_Rev.03\_2017\_02-08.docx

SAMSON AKTIENGESELLSCHAFT  
Weismüllerstraße 3 60314 Frankfurt am Main

Telefon: 069 4009-0 Telefax: 069 4009-1507  
E-Mail: samson@samson.de

Revision 03



## 15 Appendix

### 15.1 Tightening torques

**Table 15-1:** *Tightening torque*

Component	Width across flats	Valve size	Tightening torque in Nm
Seat (5)	–	G ½ to G 1 · DN 15 to 25 ½ NPT to 1 NPT	45
	–	DN 32 to 50	110
Stopper (35)	A/F 19	G ½ to G 1 · DN 15 to 25 ½ NPT to 1 NPT	40
	A/F 39	DN 32 to 50	110
Guide nipple (38)	A/F 19	G ½ to G 1 · DN 15 to 25 ½ NPT to 1 NPT	80
		DN 32 to 50	110
Coupling nut (40)	A/F 36	All	20

### 15.2 Tools

Tool	Valve size	Seat bore	Order no.
Plug wrench	G ½ to G 1 · DN 15 to 25 ½ NPT to 1 NPT	–	1280-3001
	DN 32 to 50	–	1280-3007
Seat wrench	G ½ to G 1 · DN 15 to 25 ½ NPT to 1 NPT	Seat bore 4 to 12	9932-3322
		Seat bore 20	1280-3013
	DN 32 to 50	Seat bore 40	1280-3014

### 15.3 Lubricants

SAMSON's After-sales Service can support you concerning lubricants and sealants approved by SAMSON.

## 15.4 Spare parts

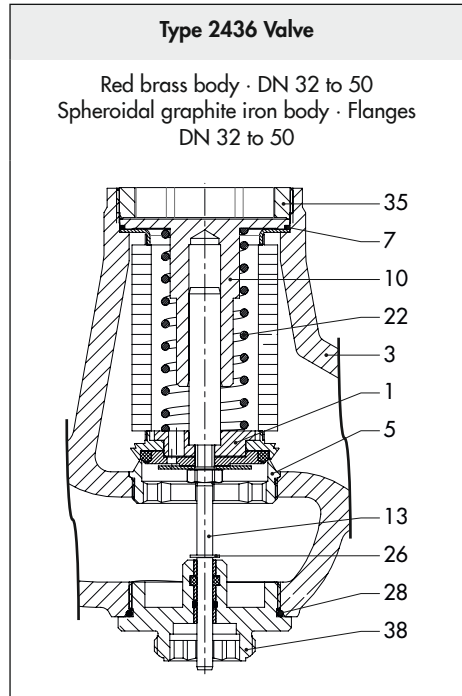
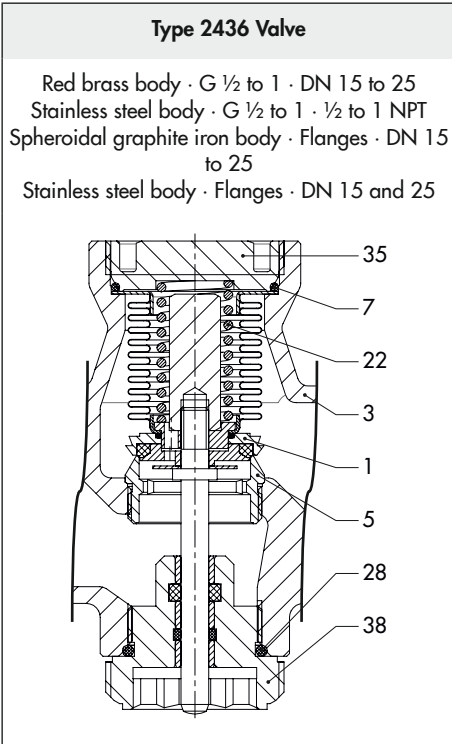

- 1 Plug assembly
- 3 Body
- 5 Seat
- 7 Seal
- 10 Guide bushing
- 13 Pin
- 22 Valve spring
- 26 Retaining washer
- 28 Seal
- 35 Stopper
- 38 Guide nipple



## 15.5 After-sales service

Contact SAMSON's After-sales Service for support concerning service or repair work or when malfunctions or defects arise.

### E-mail address

You can reach our after-sales service at [aftersalesservice@samsongroup.com](mailto:aftersalesservice@samsongroup.com).

### Addresses of SAMSON AG and its subsidiaries

The addresses of SAMSON, its subsidiaries, representatives and service facilities worldwide can be found on our website (▶ [www.samsongroup.com](http://www.samsongroup.com)) or in all SAMSON product catalogs.

### Required specifications

Please submit the following details:

- Type and nominal size of the valve
- Type ... Control Thermostat
- Model number or material number
- Upstream and downstream pressure
- Temperature and process medium
- Min. and max. flow rate in m<sup>3</sup>/h
- Is a strainer installed?
- Installation drawing showing the exact location of the regulator and all the additionally installed components (shut-off valves, pressure gauge etc.)





**EB 2172 EN**



SAMSON AKTIENGESELLSCHAFT  
Weismüllerstraße 3 · 60314 Frankfurt am Main, Germany  
Phone: +49 69 4009-0 · Fax: +49 69 4009-1507  
samson@samsongroup.com · www.samsongroup.com